



TOWN OF PUTNAM VALLEY

Town Board Work Session

April 10th, 2024

Town Hall

5 PM

~~~~~

Meeting called to Order

Pledge of Allegiance

1. Approve and Accept Updated Procurement Plan
2. Discuss Proposed Towing Law
3. Accept Soil Testing, Inc. Proposal re Wiccopee Road Bridge Replacement
4. Accept Soil Testing, Inc. Proposal re Brookfalls Road Bridge Replacement
5. Accept Soil Testing, Inc. Proposal re Bell Hollow Road Bridge Replacement
6. Accept Soil Testing, Inc. Proposal re New Hill Bridge Replacement
7. Approve Addendum to Intermunicipal Agreement with Putnam County
8. Districts:
  - a. Approve Brookdale Gardens Spring Cleanup 2024
  - b. Request to Waive Building Department Permit Fees for the Wildwood Knolls Water Tank and Shed Demolition
  - c. Request to Waive all Permit Fees for the Lake Peekskill Carraras Beach Drainage Project
  - d. Appoint RBL Superintendent for 2024 Season
  - e. Award the District Property Grass Cutting Bid 2024
  - f. Approve Emergency Repair at LPID Community Center
  - g. Adopt 2024 Wildwood Knolls Facilities Warrant
  - h. Appoint LPID Temporary Help
9. Highway:
  - a. Approve Surplus Equipment List for Auction
  - b. Approve New Equipment Purchase
10. Parks & Recreation: Approve When I Work Agreement for Lifeguards App
11. Community Media Department: Approve TelVue Corporation Proposal
12. Daily Fee Report: Summary March 1, 2024 – March 31, 2024
13. Budget Transfers and Amendments

Adjournment

Next Town Board Meeting: Wednesday, April 17<sup>th</sup>, 2024 6 PM



1

**JACQUELINE ANNABI**  
TOWN SUPERVISOR

---

TO: TOWN BOARD  
FROM: JACQUELINE ANNABI, TOWN SUPERVISOR  
SUBJECT: Procurement Plan  
DATE: April 1, 2024

---

RESOLVE, that the Town Board approve and accept the attached updated Procurement Policy for the Town of Putnam Valley.

PROCUREMENT POLICY AND PROCEDURES  
FOR THE TOWN OF PUTNAM VALLEY

**Section 1. Policy Intent.**

This procurement Policy is adopted pursuant to the provisions of General Municipal Law Section 104-b. The purpose of this Policy is to define the circumstances under which supplies, equipment and public works contracts may be let in the Town of Putnam Valley when those goods and services or public works are not required by law to be procured pursuant to the competitive bidding requirements of Section 103 of the General Municipal Law. These policies and procedures have been adopted in the best interest of the taxpayers to facilitate the acquisition of goods and services of maximum quality at the lowest possible cost, and to guard against favoritism, improvidence, extravagance, fraud and corruption.

**Section 2. Evaluation of Purchases.**

- a. Every prospective purchase of goods to be made must be initially reviewed to determine whether it is a purchase contract or a public works contract. Once determination is made, a good faith effort shall be made to determine whether it is known, or can reasonably be expected, that the aggregate amount to be spent on the item of supply or service is not subject to the competitive building requirements of General Municipal Law (“GML”) Section 103, taking into account past purchases and the aggregate amount to be spent in a year. Purchases must be supported by sufficient funds in the budget.
- b. The following items are not subject to competitive bidding pursuant to Section 103 of the General Municipal Law: purchase contracts of \$20,000 or less and public works contracts of \$35,000 or less; emergency purchases (pursuant to GML Section 103 (4)); certain municipal hospital purchases; goods purchased from agencies for the blind or severely handicapped; goods purchased from correctional institutions; purchases under State and County contracts; purchase contracts, that are from sole source providers (a sole source provider being a provider or vendor that has been determined to be the only source of the goods or services that are to be obtained or provided); surplus and second-hand purchases from another government entity; leases of equipment with operators under the control and supervision of Town officers and employees, professional services; and insurance.
- c. The Town must first explore and exhaust purchase options under State, Federal and County Contracts, surplus and second-hand purchases from other government entities, certain municipal hospital purchases, goods purchased from agencies for the blind or severely handicapped and goods purchased from correctional institutions.
- d. Local Governments can utilize contracts that are awarded by other governmental agencies, called “piggybacking”. These include other State, Federal and certain other government contracts. Use of these contracts constitutes an exemption to competitive bidding and offering requirements of the law. Purchase Orders are required, the contract number should be included on purchase order.

- e. The decision that a purchase is not subject to competitive bidding will be documented in writing by the individual making the purchase. This document may include written or verbal quotes from vendors, a memo from the purchaser indicating how the decision was arrived at, a copy of the contract indicating the source which makes the item or service exempt, a memo from the purchaser detailing the circumstances, which led to an emergency purchase or any other written documentation that is appropriate. If the purchase is approved for the contractors awarded by resolution of the Town Board; the Town Board shall state the reason why the purchase was not subject to competitive bidding.
- f. Leases which in substance are really purchases will be considered purchases for competitive bidding purposes and for compliance with this procurement policy.
- g. Installment purchase contract for equipment, machinery and apparatus are subject to competitive bidding requirements and for compliance with this procurement policy. Lease arrangements, where the purchase price is less than a reasonably accurate estimate of fair market value of the equipment at the time of purchase, so that a component of the annual rental charge is really an installment payment towards the purchase of the equipment including arrangements where there is a normal purchase price or where title will automatically pass, is to be considered an installment purchase.
- h. Where a true rental or lease agreement includes provision for separate service or maintenance charges in addition to rental charges, the service and maintenance aspect constitutes a separate public works contract subject to competitive bidding requirements and compliance with this procurement policy. However, where service and maintenance are purely incidental to the rental agreement and no separate charge is fixed, competitive bidding would not be involved.

### **Section 3. Methods for securing Goods and Services.**

- a. All goods and services not subject to competitive bidding will be secured by use of written request for proposals, written quotations, verbal quotations or any other method that assures that goods will be purchased at the lowest price and that favoritism will be avoided. Whenever possible, requests or quotations will be solicited for local vendors and contractors to whom special consideration shall be extended in the awarding of contracts. Local contractors desiring to be considered for such work may submit notice of their intent and qualifications to the Town Board and Highway Superintendent.
- b. The following methods of purchase shall be used when required by this policy in order to achieve fair and reasonable pricing and the highest savings: (See Section 2a for Accumulation of purchases):

| <b><u>Estimated amount of Purchase Contract</u></b> | <b><u>Method</u></b>                                                                                                               |
|-----------------------------------------------------|------------------------------------------------------------------------------------------------------------------------------------|
| Less than \$1,000                                   | Left to the discretion of the department                                                                                           |
| \$1,000 to \$3,000                                  | Oral request for the goods and oral/fax/quotes from two (2) vendors.                                                               |
| \$3,000 to \$20,000                                 | A written Request for Proposal (RFP) and written/fax/quotes from three (3) vendors, after obtaining authorization from Town Board. |
| Over \$20,000                                       | Competitive bids pursuant to General Municipal law §103, after obtaining authorization from Town Board                             |

| <b><u>Estimated amount of Public Works Contract</u></b> | <b><u>Method</u></b>                                                                                           |
|---------------------------------------------------------|----------------------------------------------------------------------------------------------------------------|
| Less than \$3,000                                       | Oral request for the services and oral/fax/quotes from three (3) contractors                                   |
| \$3,000 to \$10,000                                     | Written/fax/proposals from three (3) contractors, after obtaining authorization from Town Board                |
| \$10,000 to \$35,000                                    | Written RFP and written/fax/proposals from three (3) contractors after obtaining authorization from Town Board |
| Over 35,000                                             | Competitive bids pursuant to General Municipal law §103 after obtaining authorization from Town Board          |

- c. Any written RFP shall describe the desired goods, quantity and the particulars of delivery. The purchaser shall compile a list of all vendors from whom written/fax/oral quotes have been requested and the written/fax/oral quotes offers.
- d. A good faith effort shall be made to obtain the required number of proposals or quotations. If the purchaser is unable to obtain the required number of proposals or quotations, the purchaser will document the attempt made at obtaining the proposals. In no event shall the failure to obtain the proposals be a bar to procurement.
- e. All information gathered in complying with the procedures of this policy shall be preserved and filed with the documentation supporting the subsequent purchase or public works contract.

- f. The Lower responsible proposal or quote shall be awarded the purchase or public works contract unless the purchaser prepared a written justification providing reasons why it is in the best interest of the Town and its taxpayers to make an award to other than the low proposer. Such justification may give special consideration to local vendors or contractors pursuant to Section 3(a). If a proposer is not deemed responsible, facts supporting that judgment shall also be documented and filed with the records supporting the procurement. In order to minimize and /or preclude these situations, it is expected that the purchaser would not solicit quotes from suppliers previously deemed unacceptable due to justifiable reasons.

#### **Section 4. Exceptions.**

The solicitation of alternative proposals or quotations shall not be required in the best interests of the municipality in the following circumstances where proper qualifications are not necessarily found in the individual or company that offers the lowest price and the nature of these services are such that they do not readily lend themselves to competitive procurement procedures:

- a. Professional services or services requiring special or technical skill, training or expertise – The individual or company must be chosen based on accountability, reliability, responsibility, skill, education and training, judgment, integrity and moral worth. In determining whether a service shall fit into this category, the Town Board shall take into consideration the following guidelines:
  - (1) Whether the services are subject to state licensing or testing requirements;
  - (2) Whether substantial formal education or training is necessary prerequisite to the performance of the services; and
  - (3) Whether the services require a personal relationship between the individual and municipal officials.
- b. Professional and technical services shall include but not be limited to the following: services of an attorney; services of a physician; technical services or architect engaged to prepare plans, maps and estimates; securing insurance coverage and /or services of an insurance broker; services of a certified public accountant; investment management services; printing services involving extensive writing, editing or artwork; management of municipality owned property; and computer software or programming services for customized programs or services involved in substantial modification and customizing of prepackaged software
- c. Emergency purchases as defined in Section 103(4) of the General Municipal Law – Due to the nature of this exception, these goods or services must be purchased immediately where a delay in order to seek alternate proposals may threaten life, health, safety or welfare of the residents, this section does not preclude alternate proposals if time permits.

- d. Purchases of surplus and second-hand goods from any source – If alternate proposals are required, the town is precluded from purchasing surplus and second-hand goods at auctions or through specific advertised sources where the best prices are usually contained. It is also difficult to try to compare prices of used goods and a lower price may indicate an older product.
- e. Goods under \$1,000 and public works contracts for less than \$3,000 – The time and documentation required to purchase through this policy may be more costly than the item itself and therefore not be in the best interests of the taxpayer. In addition, it is not likely that such de minimis contracts would be awarded based on favoritism.
- f. Sole Source – When it can be justified that this supplier is the only source which can manufacture a product or provide a service so that there is no possibility of competition (i.e., patent, directed by law, possesses unique expertise).
- g. Single Source – Source identified as the result of previous standardization of a specific purchase when there are no other suppliers of that item for the Town service area.
- h. Lease of equipment so long as the project is under the complete control and supervision of the Town. However, in such event competitive proposals are to be solicited from vendors who can provide a similar type service when the Town wishes to make such leases or rentals in the future; and any lease or rental rates shall be subject to the prior approval of the Town Supervisor.
- i. No portion of this policy shall be construed as preventing the competitive bidding of purchase contracts under \$20,000 or public works projects under \$35,000, if so desired by the Town Board.
- j. The unintentional failure to fully comply with the provisions of this Procurement Policy shall not be grounds to void action taken or give rise to a cause of action against the Town of Putnam Valley or any office or employee.

#### **Section 5. Town Board Approval**

Where the purchase cost of the items exceeds the sum of \$3,000 for public works contract and exceeds \$1,000 for a purchase, no officer or employee of the Town shall purchase on behalf of the Town, unless and until a majority of the members of the Town Board shall have voted, in advance, to approve such purchase or such order.

#### **Section 6. Policy Review**

This policy shall be reviewed annually, unless otherwise prescribed by law, by the Town Board at its organizational meeting or as soon thereafter, as is reasonably practicable.





3

**JACQUELINE ANNABI**  
TOWN SUPERVISOR

---

TO: TOWN BOARD  
FROM: JACQUELINE ANNABI, TOWN SUPERVISOR  
SUBJECT: Wicopee Road Bridge Replacement Proposal  
DATE: April 1, 2024

---

RESOLVE, that the Town Board approve and accept the proposal from Soil Testing, Inc. to conduct subsurface investigations for the Wicopee Road Bridge Replacement Project totaling \$27,020.00. This project is necessary due to the storm of July 10, 2023 and appropriation of funding for the same will be covered by FEMA.

Phone  
(203) 262-9328

Telefax  
(203) 264-3414

WHITE PLAINS, N.Y.  
(914) 946-4850



# SOILTESTING, INC.

90 DONOVAN ROAD - OXFORD, CONN. 06478-1028

**GEOTECHNICAL / ENVIRONMENTAL SUBSURFACE INVESTIGATIONS - Test Borings - Core Drilling  
Monitoring Wells - Recovery Wells - Direct Push/Probe Sampling  
UNDERPINNING - HELICAL PILES - SOIL NAILS**

April 1, 2024

J. Robet Folchetti & Associates LLC  
31 Sodom Road  
Brewster NY 10509  
845-363-1560 / 845-224-9347 cell

Attn: Todd Atkinson, PE

Re: Wicopee Rd. Bridge Replacement  
Putnam Valley NY

Dear Mr. Atkinson,

We herein submit our proposal to conduct subsurface investigations for the above referenced project site.

Our proposal is as follows:

**Estimated Quantities:**

|                        |                                                      |   |                 |                      |                    |
|------------------------|------------------------------------------------------|---|-----------------|----------------------|--------------------|
| Lump Sum               | Mobilization: Truck-Mounted Equipment                |   |                 |                      | \$750.00           |
| 2 days                 | Truck-Mounted Equipment & Crew                       | @ | \$3,650.00 /day |                      | \$7,300.00         |
|                        | Over Time                                            | @ | \$545.00 /hour  |                      |                    |
| Lump Sum               | Mobilization: Track-Mounted Equipment                |   |                 |                      | \$900.00           |
| 2 - 3 days             | Track-Mounted Equipment & Crew                       | @ | \$4,050.00 /day | \$8,100.00 -         | \$12,150.00        |
|                        | Over Time                                            | @ | \$595.00 /hr    |                      |                    |
| 1 - 2 ea               | NW Casing Shoe                                       | @ | \$315.00 /ea    | \$315.00 -           | \$630.00           |
| 25 lf                  | NX Rock Core in Bedrock or Boulder                   | @ | \$38.00 /lf     |                      | \$950.00           |
| 2 ea                   | NX Core Box                                          | @ | \$38.00 /ea     |                      | \$76.00            |
| 5 bags                 | Portland Cement                                      | @ | \$24.00 /bag    |                      | \$120.00           |
| 3 bags                 | HD Asphalt / Perma Patch                             | @ | \$48.00 /bag    |                      | \$144.00           |
|                        | Permits & Bonds at Cost + 20%                        |   |                 |                      |                    |
|                        | Traffic Control - By Others                          |   |                 |                      |                    |
|                        | Grading for Access to B-1, 2, 6, 11 & 12 - By Others |   |                 |                      |                    |
|                        | Staking of Boring Locatons - By Others               |   |                 |                      |                    |
|                        | Site Visit for Grading work (if requested)           | @ | \$485.00 /visit |                      |                    |
| Lump Sum               | Geotechnical Report & Recommendations                |   |                 |                      | \$4,000.00         |
| <b>Estimated Total</b> |                                                      |   |                 | <b>\$22,655.00 -</b> | <b>\$27,020.00</b> |

This project is anticipated to include 9 Test Borings (B-1 omitted from scope):

- 4 Borings to depths of 35' or 5' into Bedrock.
- 6 Borings to depths of 20' or refusal.

Any required permits not listed above will be billed at cost + 20%.

The above outlined costs includes prevailing wage rates.

**If the preceding proposal meets with your approval, please forward a signed copy to our office prior to mobilization.**

April 1, 2024  
Page 2

Re: Wiccopee Rd. Bridge Replacement  
Putnam Valley NY

All borings will be backfilled to surface upon completion. Settlement of boreholes after backfilling should be expected, however grouting of borehole immediately following drilling procedures should reduce the likelihood of settlement. Frequent inspection of all boring locations for settlement should be performed along with any necessary filling, packing, and patching, and is the responsibility of the owner and/or owner's representative. We will be happy to assist the owner with this maintenance and/or provide a cost estimate for grouting of boreholes upon request.

The owner and/or owner's representative will be responsible for markout and clearance of any and all underground utilities at boring locations. Any damage or injuries due to disruption to any underground utilities will be the responsibility of the owner or owner's representative. If you require assistance from us, we would be happy to help you once we are notified in writing at least 72 hours prior to mobilization.

SUBSURFACE EXPLORATIONS- Normal disturbance: Client hereby recognizes that the use of exploration equipment may unavoidably affect, alter, or damage the terrain and affect vegetation, building, structures, and equipment in, at, or upon the site. Client accepts the fact that this is inherent in Soiltesting, Inc's work and will not hold Soiltesting, Inc liable or responsible for any such reasonable effect, alteration, or damage. Soiltesting Inc. will take reasonable precautions to limit damage to site, but the cost of restoration of damage that may result from such operations has not been included in Soiltesting Inc's fee. If Soiltesting Inc is requested to restore the land to its former conditions, the cost of restoration will be borne by the Client as an additional fee(in addition to others costs).

Damage to Existing Subterranean Structures: Soiltesting Inc will exercise due and responsible care of local subterranean structures in the vicinity of where subsurface explorations are made. This will include contact with appropriate public utilities(through code 753) and review of plans and information provided by public agencies, along with contact with Client and Owner of the site relating to the location of subterranean structures. Provided that Soiltesting, Inc has proceeded with due and reasonable care, Soiltesting Inc cannot be liable for damages or injury arising from damage to or interference with subterranean structures(including, without limitation, pipes, tanks, telephone cables, etc.) that are not called to Soiltesting Inc's attention or not correctly shown on the plans furnished by Client or others in connection with work performed under this agreement.

The above outlined costs have assumed that this project is exempt from sales tax. If this project is not exempt, then the appropriate sales tax will be added to the final invoice.

Payment of all fees is expected upon receipt of the invoice. Balances due are subject to a service charge of 1½% per month after thirty days of the date of invoice. All charges associated with the collection of fees shall become part of the total fee.

We thank you for the opportunity to submit this proposal. If you have any questions, please do not hesitate to contact me.

Very truly yours,

**SOILTESTING, INC.**

James A. DeAngelis  
Engineering Geologist

JAD:

THIS PROPOSAL IS UNDERSTOOD AND ACCEPTED:

Owner or Owners Representative (\*) (Please sign and print name.)

Billing Address/email: \_\_\_\_\_

EMAIL(REQUIRED):

Telephone Number: \_\_\_\_\_ Date: \_\_\_\_\_



(\*) Confirms above statement is correct.

Re: Wiccopee Rd. Bridge Replacement  
Putnam Valley NY

**Certificate of Insurance Requirements for this project:**

Certificate Holder (name, address, phone email):

\_\_\_\_\_  
\_\_\_\_\_  
\_\_\_\_\_

Additional Insured:

\_\_\_\_\_  
\_\_\_\_\_

*Please fill in the above requirements for your project. Allow 24-48 hours for insurer to issue COI from receipt of above information*

*Note: failure to complete insurance certificate requirements will result in a default COI being issued with addressee as certificate owner as well as additional insured.*

**Drilling Services Sales Tax Status:**

Please mark the appropriate box below for Sales tax purposes, return this sheet with your signed proposal.

|                                     | <u>Exempt</u>            | <u>Subject to<br/>Sales Tax</u> |
|-------------------------------------|--------------------------|---------------------------------|
| <b><u>DRILLING LABOR</u></b>        |                          |                                 |
| Tax Exempt Entity                   | <input type="checkbox"/> | <input type="checkbox"/>        |
| Municipal                           | <input type="checkbox"/> | <input type="checkbox"/>        |
| Residential                         | <input type="checkbox"/> | <input type="checkbox"/>        |
| Commercial - New Construction       | <input type="checkbox"/> | <input type="checkbox"/>        |
| Industrial - New Construction       | <input type="checkbox"/> | <input type="checkbox"/>        |
| Income Producing - New Construction | <input type="checkbox"/> | <input type="checkbox"/>        |
| Commercial - Existing               | <input type="checkbox"/> | <input type="checkbox"/>        |
| Industrial - Existing               | <input type="checkbox"/> | <input type="checkbox"/>        |
| Income Producing - Existing         | <input type="checkbox"/> | <input type="checkbox"/>        |

Thank you,  
**SOILTESTING, INC.**

Soiltesting Inc. will not discriminate or permit discrimination against any person or group of persons on the grounds of race, color, religious creed, age, marital status, national origin, ancestry, sex, gender identity or expression, intellectual disability, mental disability or physical disability, including, but not limited to, blindness, unless it is shown by such contractor that such disability prevents performance of the work involved, in any manner prohibited by the laws of the United States or of the state of Connecticut; and the contractor further agrees to take affirmative action to insure that applicants with job-related qualifications are employed and that employees are treated when employed without regard to their race, color, religious creed, age, marital status, national origin, ancestry, sex, gender identity or expression, intellectual disability, mental disability or physical disability, including, but not limited to, blindness, unless it is shown by such contractor that such disability prevents performance of the work involved; Soiltesting Inc. is an affirmative action-equal opportunity employer.

return this page with your signed contract prior to Mobilization.





4

**JACQUELINE ANNABI**  
TOWN SUPERVISOR

---

TO: TOWN BOARD  
FROM: JACQUELINE ANNABI, TOWN SUPERVISOR  
SUBJECT: Brookfalls Road Bridge Replacement Proposal  
DATE: April 4, 2024

---

RESOLVE, that the Town Board approve and accept the proposal from Soil Testing, Inc. to conduct subsurface investigations for the Brookfalls Road Bridge Replacement Project totaling \$18,088.00. This project is necessary due to the storm of July 10, 2023 and appropriation of funding for the same will be covered by FEMA.

Phone  
(203) 262-9328

Telefax  
(203) 264-3414

WHITE PLAINS, N.Y.  
(914) 946-4850



# SOILTESTING, INC.

90 DONOVAN ROAD - OXFORD, CONN. 06478-1028

**GEOTECHNICAL / ENVIRONMENTAL SUBSURFACE INVESTIGATIONS - Test Borings - Core Drilling  
Monitoring Wells - Recovery Wells - Direct Push/Probe Sampling  
UNDERPINNING - HELICAL PILES - SOIL NAILS**



April 1, 2024

J. Robert Folchetti & Associates LLC  
31 Sodom Road  
Brewster NY 10509  
845-363-1560 / 845-224-9347 cell

Attn: Todd Atkinson, PE

Re: Brookfalls Road Bridge Replacement  
Putnam Valley NY

Dear Mr. Atkinson,

We herein submit our proposal to conduct subsurface investigations for the above referenced project site.  
Our proposal is as follows:

**Estimated Quantities:**

|                              |                                             |   |                 |                    |
|------------------------------|---------------------------------------------|---|-----------------|--------------------|
| Lump Sum                     | Mobilization: ATV-Mounted Equipment         |   |                 | \$900.00           |
| 3 days                       | ATV-Mounted Equipment & Crew                | @ | \$4,050.00 /day | \$12,150.00        |
|                              | Over Time                                   | @ | \$595.00 /hour  |                    |
|                              | NW Casing Shoe                              | @ | \$315.00 /ea    |                    |
| 20 lf                        | NX Rock Core in Bedrock or Boulder          | @ | \$38.00 /lf     | \$760.00           |
| 1 ea                         | NX Core Box                                 | @ | \$38.00 /ea     | \$38.00            |
| 6 bags                       | Portland Cement                             | @ | \$24.00 /bag    | \$144.00           |
| 2 bags                       | HD Asphalt / Perma Patch                    | @ | \$48.00 /bag    | \$96.00            |
|                              | Permits & Bonds at Cost + 20%               |   |                 |                    |
|                              | Traffic Control - By Others                 |   |                 |                    |
|                              | Grading for Access to B-1, 3, 6 - By Others |   |                 |                    |
|                              | Site Visit for Grading work (if required)   | @ | \$485.00 /visit |                    |
|                              | Staking of Boring Locatons - By Others      |   |                 |                    |
| Lump Sum                     | Geotechnical Report & Recommendations       |   |                 | \$4,000.00         |
| <b>Estimated Total .....</b> |                                             |   |                 | <b>\$18,088.00</b> |

This project is anticipated to include:

- 6 Test Borings to depths of 35' or 5' into Bedrock.

Any required permits not listed above will be billed at cost + 20%.

The above outlined costs includes prevailing wage rates.

**If the preceding proposal meets with your approval, please forward a signed copy to our office prior to mobilization.**

Re: Brookfalls Road Bridge Replacement  
Putnam Valley NY

All borings will be backfilled to surface upon completion. Settlement of boreholes after backfilling should be expected, however grouting of borehole immediately following drilling procedures should reduce the likelihood of settlement. Frequent inspection of all boring locations for settlement should be performed along with any necessary filling, packing, and patching, and is the responsibility of the owner and/or owner's representative. We will be happy to assist the owner with this maintenance and/or provide a cost estimate for grouting of boreholes upon request.

The owner and/or owner's representative will be responsible for markout and clearance of any and all underground utilities at boring locations. Any damage or injuries due to disruption to any underground utilities will be the responsibility of the owner or owner's representative. If you require assistance from us, we would be happy to help you once we are notified in writing at least 72 hours prior to mobilization.

**SUBSURFACE EXPLORATIONS-** Normal disturbance: Client hereby recognizes that the use of exploration equipment may unavoidably affect, alter, or damage the terrain and affect vegetation, building, structures, and equipment in, at, or upon the site. Client accepts the fact that this is inherent in Soiltesting, Inc's work and will not hold Soiltesting, Inc liable or responsible for any such reasonable effect, alteration, or damage. Soiltesting Inc. will take reasonable precautions to limit damage to site, but the cost of restoration of damage that may result from such operations has not been included in Soiltesting Inc's fee. If Soiltesting Inc is requested to restore the land to its former conditions, the cost of restoration will be borne by the Client as an additional fee(in addition to others costs).

Damage to Existing Subterranean Structures: Soiltesting Inc will exercise due and responsible care of local subterranean structures in the vicinity of where subsurface explorations are made. This will include contact with appropriate public utilities(through code 753) and review of plans and information provided by public agencies, along with contact with Client and Owner of the site relating to the location of subterranean structures. Provided that Soiltesting, Inc has proceeded with due and reasonable care, Soiltesting Inc cannot be liable for damages or injury arising from damage to or interference with subterranean structures(including, without limitation, pipes, tanks, telephone cables, etc.) that are not called to Soiltesting Inc's attention or not correctly shown on the plans furnished by Client or others in connection with work performed under this agreement.

The above outlined costs have assumed that this project is exempt from sales tax. If this project is not exempt, then the appropriate sales tax will be added to the final invoice.

Payment of all fees is expected upon receipt of the invoice. Balances due are subject to a service charge of 1½% per month after thirty days of the date of invoice. All charges associated with the collection of fees shall become part of the total fee.

We thank you for the opportunity to submit this proposal. If you have any questions, please do not hesitate to contact me.

Very truly yours,

**SOILTESTING, INC.**

  
James A. DeAngelis  
Engineering Geologist

JAD:

THIS PROPOSAL IS UNDERSTOOD AND ACCEPTED:

Owner or Owners Representative (\*) (Please sign and print name.)  
Jacqueline Annabi, Supervisor, Town of Putnam Valley  
Billing Address/email: Town of Putnam Valley  
265 Oscawana Lake Road  
Putnam Valley, NY 10579

EMAIL(REQUIRED): jannabi@putnamvalley.gov  
Telephone Number: 845-526-2121 Date: April, 2024



(\*) Confirms above statement is correct.

Re: Brookfalls Road Bridge Replacement  
Putnam Valley NY

**Certificate of Insurance Requirements for this project:**

Certificate Holder (name, address, phone email):

\_\_\_\_\_  
\_\_\_\_\_  
\_\_\_\_\_

Additional Insured:

\_\_\_\_\_  
\_\_\_\_\_

*Please fill in the above requirements for your project. Allow 24-48 hours for insurer to issue COI from receipt of above information*

***Note: failure to complete insurance certificate requirements will result in a default COI being issued with addressee as certificate owner as well as additional insured.***

**Drilling Services Sales Tax Status:**

Please mark the appropriate box below for Sales tax purposes, return this sheet with your signed proposal.

|                                     | <u>Exempt</u>            | <u>Subject to<br/>Sales Tax</u> |
|-------------------------------------|--------------------------|---------------------------------|
| <b><u>DRILLING LABOR</u></b>        |                          |                                 |
| Tax Exempt Entity                   | <input type="checkbox"/> | <input type="checkbox"/>        |
| Municipal                           | <input type="checkbox"/> | <input type="checkbox"/>        |
| Residential                         | <input type="checkbox"/> | <input type="checkbox"/>        |
| Commercial - New Construction       | <input type="checkbox"/> | <input type="checkbox"/>        |
| Industrial - New Construction       | <input type="checkbox"/> | <input type="checkbox"/>        |
| Income Producing - New Construction | <input type="checkbox"/> | <input type="checkbox"/>        |
| Commercial - Existing               | <input type="checkbox"/> | <input type="checkbox"/>        |
| Industrial - Existing               | <input type="checkbox"/> | <input type="checkbox"/>        |
| Income Producing - Existing         | <input type="checkbox"/> | <input type="checkbox"/>        |

Thank you,

**SOILTESTING, INC.**

Soiltesting Inc. will not discriminate or permit discrimination against any person or group of persons on the grounds of race, color, religious creed, age, marital status, national origin, ancestry, sex, gender identity or expression, intellectual disability, mental disability or physical disability, including, but not limited to, blindness, unless it is shown by such contractor that such disability prevents performance of the work involved, in any manner prohibited by the laws of the United States or of the state of Connecticut; and the contractor further agrees to take affirmative action to insure that applicants with job-related qualifications are employed and that employees are treated when employed without regard to their race, color, religious creed, age, marital status, national origin, ancestry, sex, gender identity or expression, intellectual disability, mental disability or physical disability, including, but not limited to, blindness, unless it is shown by such contractor that such disability prevents performance of the work involved; Soiltesting Inc. is an affirmative action-equal opportunity employer.

return this page with your signed contract prior to Mobilization.







5

**JACQUELINE ANNABI**  
TOWN SUPERVISOR

---

TO: TOWN BOARD  
FROM: JACQUELINE ANNABI, TOWN SUPERVISOR  
SUBJECT: Bell Hollow Road Bridge Replacement Proposal  
DATE: April 4, 2024

---

RESOLVE, that the Town Board approve and accept the proposal from Soil Testing, Inc. to conduct subsurface investigations for the Bell Hollow Road Bridge Replacement Project totaling no more than \$9,945.00. This project is necessary due to the storm of July 10, 2023 and appropriation of funding for the same will be covered by FEMA.

Phone  
(203) 262-9328

Telefax  
(203) 264-3414

WHITE PLAINS, N.Y.  
(914) 946-4850



# SOILTESTING, INC.

90 DONOVAN ROAD - OXFORD, CONN. 06478-1028

**GEOTECHNICAL / ENVIRONMENTAL SUBSURFACE INVESTIGATIONS - Test Borings - Core Drilling  
Monitoring Wells - Recovery Wells - Direct Push/Probe Sampling  
UNDERPINNING - HELICAL PILES - SOIL NAILS**



March 28, 2024

Town of Putnam Valley  
265 Oscawana Lake Road  
Putnam Valley, NY 10579

Attn: Todd Atkinson, P. E.  
845-363-1560/cell: 845-224-9347

Re: Bell Hollow Rd  
Putnam Valley, NY

Dear Mr. Atkinson,

We herein submit our proposal to conduct subsurface investigations for the above referenced project site.  
Our proposal is as follows:

**Estimated Quantities:**

|                              |                                                                             |   |                 |                     |                   |
|------------------------------|-----------------------------------------------------------------------------|---|-----------------|---------------------|-------------------|
| Lump Sum                     | Mobilization: Track-Mounted Equipment                                       |   |                 |                     | \$900.00          |
| 1 - 2 days                   | Track-Mounted Equipment & Crew                                              | @ | \$4,080.00 /day | \$4,080.00 -        | \$8,160.00        |
|                              | Over Time                                                                   | @ | \$595.00 /hour  |                     |                   |
| .5 - 1 ea                    | NW Casing Shoe                                                              | @ | \$315.00 /ea    | \$ 157.50 -         | \$315.00          |
| 10 - 15 lf                   | NX (2 1/8") Rock Core                                                       | @ | \$38.00 /lf     | \$ 380.00 -         | \$570.00          |
|                              | Grading for Access to B-7 Location-By Others                                |   |                 |                     |                   |
|                              | Staking of Boring Locations- By Others                                      |   |                 |                     |                   |
|                              | Supplemental Geotechnical Report & Recommendations (if requested) LS \$2500 |   |                 |                     |                   |
| <b>Estimated Total .....</b> |                                                                             |   |                 | <b>\$5,517.50 -</b> | <b>\$9,945.00</b> |

This project is anticipated to include:

- 4 Borings: 2 to 35' or 5' into Bedrock & 2 to 20' or refusal

Any required permits not listed above will be billed at cost + 20%.

The above outlined costs have assumed that this project/work is subject to prevailing wage rates(\*).

**If the preceding proposal meets with your approval, please forward a signed copy to our office prior to mobilization.**

March 28, 2024

Page 2

Re: Bell Hollow Rd  
Putnam Valley, NY

All borings will be backfilled to surface upon completion. Settlement of boreholes after backfilling should be expected, however grouting of borehole immediately following drilling procedures should reduce the likelihood of settlement. Frequent inspection of all boring locations for settlement should be performed along with any necessary filling, packing, and patching, and is the responsibility of the owner and/or owner's representative. We will be happy to assist the owner with this maintenance and/or provide a cost estimate for grouting of boreholes upon request.

The owner and/or owner's representative will be responsible for markout and clearance of any and all underground utilities at boring locations. Any damage or injuries due to disruption to any underground utilities will be the responsibility of the owner or owner's representative. If you require assistance from us, we would be happy to help you once we are notified in writing at least 72 hours prior to mobilization.

SUBSURFACE EXPLORATIONS- Normal disturbance: Client hereby recognizes that the use of exploration equipment may unavoidably affect, alter, or damage the terrain and affect vegetation, building, structures, and equipment in, at, or upon the site. Client accepts the fact that this is inherent in Soiltesting, Inc's work and will not hold Soiltesting, Inc liable or responsible for any such reasonable effect, alteration, or damage. Soiltesting Inc. will take reasonable precautions to limit damage to site, but the cost of restoration of damage that may result from such operations has not been included in Soiltesting Inc's fee. If Soiltesting Inc is requested to restore the land to its former conditions, the cost of restoration will be borne by the Client as an additional fee(in addition to others costs).

Damage to Existing Subterranean Structures: Soiltesting Inc will exercise due and responsible care of local subterranean structures in the vicinity of where subsurface explorations are made. This will include contact with appropriate public utilities(through code 753) and review of plans and information provided by public agencies, along with contact with Client and Owner of the site relating to the location of subterranean structures. Provided that Soiltesting, Inc has proceeded with due and reasonable care, Soiltesting Inc cannot be liable for damages or injury arising from damage to or interference with subterranean structures(including, without limitation, pipes, tanks, telephone cables, etc.) that are not called to Soiltesting Inc's attention or not correctly shown on the plans furnished by Client or others in connection with work performed under this agreement.

The above outlined costs have assumed that this project is exempt from sales tax. If this project is not exempt, then the appropriate sales tax will be added to the final invoice.

Payment of all fees is expected upon receipt of the invoice. Balances due are subject to a service charge of 1½% per month after thirty days of the date of invoice. All charges associated with the collection of fees shall become part of the total fee.

We thank you for the opportunity to submit this proposal. If you have any questions, please do not hesitate to contact me.

Very truly yours,

**SOILTESTING, INC.**

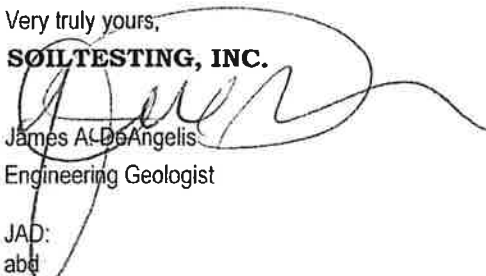
  
James A. DeAngelis  
Engineering Geologist

JAD:  
abd

THIS PROPOSAL IS UNDERSTOOD AND ACCEPTED:

Owner or Owners Representative (\*) (Please sign and print name.)  
Jacqueline Annabi, Supervisor, Town of Putnam Valley  
Billing Address/email: Town of Putnam Valley  
265 Oscawana Lake Road  
Putnam Valley, NY 10579

EMAIL(REQUIRED): jannabi@putnamvalley.gov

Telephone Number: 845-526-2121

Date: April , 2024



(\*) Confirms above statement is correct.

Re: Bell Hollow Rd  
Putnam Valley, NY

**Certificate of Insurance Requirements for this project:**

Certificate Holder (name, address, phone email):

\_\_\_\_\_  
\_\_\_\_\_

Additional Insured:

\_\_\_\_\_

*Please fill in the above requirements for your project. Allow 24-48 hours for insurer to issue COI from receipt of above information*

*Note: failure to complete insurance certificate requirements will result in a default COI being issued with addressee as certificate owner as well as additional insured.*

**Drilling Services Sales Tax Status:**

Please mark the appropriate box below for Sales tax purposes, return this sheet with your signed proposal.

|                                     | <u>Exempt</u>            | <u>Subject to<br/>Sales Tax</u> |
|-------------------------------------|--------------------------|---------------------------------|
| <b><u>DRILLING LABOR</u></b>        |                          |                                 |
| Tax Exempt Entity                   | <input type="checkbox"/> | <input type="checkbox"/>        |
| Municipal                           | <input type="checkbox"/> | <input type="checkbox"/>        |
| Residential                         | <input type="checkbox"/> | <input type="checkbox"/>        |
| Commercial - New Construction       | <input type="checkbox"/> | <input type="checkbox"/>        |
| Industrial - New Construction       | <input type="checkbox"/> | <input type="checkbox"/>        |
| Income Producing - New Construction | <input type="checkbox"/> | <input type="checkbox"/>        |
| Commercial - Existing               | <input type="checkbox"/> | <input type="checkbox"/>        |
| Industrial - Existing               | <input type="checkbox"/> | <input type="checkbox"/>        |
| Income Producing - Existing         | <input type="checkbox"/> | <input type="checkbox"/>        |

Thank you,  
**SOILTESTING, INC.**

Soiltesting Inc. will not discriminate or permit discrimination against any person or group of persons on the grounds of race, color, religious creed, age, marital status, national origin, ancestry, sex, gender identity or expression, intellectual disability, mental disability or physical disability, including, but not limited to, blindness, unless it is shown by such contractor that such disability prevents performance of the work involved, in any manner prohibited by the laws of the United States or of the state of Connecticut; and the contractor further agrees to take affirmative action to insure that applicants with job-related qualifications are employed and that employees are treated when employed without regard to their race, color, religious creed, age, marital status, national origin, ancestry, sex, gender identity or expression, intellectual disability, mental disability or physical disability, including, but not limited to, blindness, unless it is shown by such contractor that such disability prevents performance of the work involved; Soiltesting Inc. is an affirmative action-equal opportunity employer.

return this page with your signed contract prior to Mobilization.





6

**JACQUELINE ANNABI**  
TOWN SUPERVISOR

---

**TO:** TOWN BOARD  
**FROM:** JACQUELINE ANNABI, TOWN SUPERVISOR  
**SUBJECT:** New Hill Road Bridge Replacement Proposal  
**DATE:** April 4, 2024

---

RESOLVE, that the Town Board approve and accept the proposal from Soil Testing, Inc. to conduct subsurface investigations for the New Hill Road Bridge Replacement Project totaling \$21,733.00. This project is necessary due to the storm of July 10, 2023 and appropriation of funding for the same will be covered by FEMA.

Phone  
(203) 262-9328

Telefax  
(203) 264-3414



WHITE PLAINS, N.Y.  
(914) 946-4850

# SOILTESTING, INC.

90 DONOVAN ROAD - OXFORD, CONN. 06478-1028

**GEOTECHNICAL / ENVIRONMENTAL SUBSURFACE INVESTIGATIONS - Test Borings - Core Drilling  
Monitoring Wells - Recovery Wells - Direct Push/Probe Sampling  
UNDERPINNING - HELICAL PILES - SOIL NAILS**

April 1, 2024

J. Robert Folchetti & Associates LLC  
31 Sodom Road  
Brewster NY 10509  
845-363-1560 / 845-224-9347 cell

Attn: Todd Atkinson, PE

Re: New Hill Road Bridge Replacement  
Putnam Valley NY

Dear Mr. Atkinson,

We herein submit our proposal to conduct subsurface investigations for the above referenced project site.  
Our proposal is as follows:

**Estimated Quantities:**

|                              |                                        |   |                 |                    |
|------------------------------|----------------------------------------|---|-----------------|--------------------|
| Lump Sum                     | Mobilization: ATV-Mounted Equipment    |   |                 | \$900.00           |
| 4 days                       | ATV-Mounted Equipment & Crew           | @ | \$4,050.00 /day | \$16,200.00        |
|                              | Over Time                              | @ | \$595.00 /hour  |                    |
| 1 ea                         | 4" Drive Shoe                          | @ | \$145.00 /ea    | \$145.00           |
|                              | NX Rock Core in Bedrock or Boulder     | @ | \$38.00 /lf     | \$0.00             |
|                              | NX Core Box                            | @ | \$38.00 /ea     | \$0.00             |
| 4 bags                       | Mud Rotary Fluid                       | @ | \$38.00 /bag    | \$152.00           |
| 10 bags                      | Portland Cement                        | @ | \$24.00 /bag    | \$240.00           |
| 2 ea                         | HD Asphalt / Perma Patch               | @ | \$48.00 /bag    | \$96.00            |
|                              | Permits & Bonds at Cost + 20%          |   |                 |                    |
|                              | Traffic Control - By Others            |   |                 |                    |
|                              | Staking of Boring Locatons - By Others |   |                 |                    |
| Lump Sum                     | Geotechnical Report & Recommendations  |   |                 | \$4,000.00         |
| <b>Estimated Total .....</b> |                                        |   |                 | <b>\$21,733.00</b> |

This project is anticipated to include 10 Test Borings:

- 6 Borings to 20' or refusal.
- 4 Borings to depths of approximately 50'.

Any required permits not listed above will be billed at cost + 20%.

The above outlined costs includes prevailing wage rates.

**If the preceding proposal meets with your approval, please forward a signed copy to our office prior to mobilization.**

Re: New Hill Road Bridge Replacement  
Putnam Valley NY

All borings will be backfilled to surface upon completion. Settlement of boreholes after backfilling should be expected, however grouting of borehole immediately following drilling procedures should reduce the likelihood of settlement. Frequent inspection of all boring locations for settlement should be performed along with any necessary filling, packing, and patching, and is the responsibility of the owner and/or owner's representative. We will be happy to assist the owner with this maintenance and/or provide a cost estimate for grouting of boreholes upon request.

The owner and/or owner's representative will be responsible for markout and clearance of any and all underground utilities at boring locations. Any damage or injuries due to disruption to any underground utilities will be the responsibility of the owner or owner's representative. If you require assistance from us, we would be happy to help you once we are notified in writing at least 72 hours prior to mobilization.

SUBSURFACE EXPLORATIONS- Normal disturbance: Client hereby recognizes that the use of exploration equipment may unavoidably affect, alter, or damage the terrain and affect vegetation, building, structures, and equipment in, at, or upon the site. Client accepts the fact that this is inherent in Soiltesting, Inc's work and will not hold Soiltesting, Inc liable or responsible for any such reasonable effect, alteration, or damage. Soiltesting Inc. will take reasonable precautions to limit damage to site, but the cost of restoration of damage that may result from such operations has not been included in Soiltesting Inc's fee. If Soiltesting Inc is requested to restore the land to its former conditions, the cost of restoration will be borne by the Client as an additional fee(in addition to others costs).

Damage to Existing Subterranean Structures: Soiltesting Inc will exercise due and responsible care of local subterranean structures in the vicinity of where subsurface explorations are made. This will include contact with appropriate public utilities(through code 753) and review of plans and information provided by public agencies, along with contact with Client and Owner of the site relating to the location of subterranean structures. Provided that Soiltesting, Inc has proceeded with due and reasonable care, Soiltesting Inc cannot be liable for damages or injury arising from damage to or interference with subterranean structures(including, without limitation, pipes, tanks, telephone cables, etc.) that are not called to Soiltesting Inc's attention or not correctly shown on the plans furnished by Client or others in connection with work performed under this agreement.

The above outlined costs have assumed that this project is exempt from sales tax. If this project is not exempt, then the appropriate sales tax will be added to the final invoice.

Payment of all fees is expected upon receipt of the invoice. Balances due are subject to a service charge of 1½% per month after thirty days of the date of invoice. All charges associated with the collection of fees shall become part of the total fee.

We thank you for the opportunity to submit this proposal. If you have any questions, please do not hesitate to contact me.

Very truly yours,

**SOILTESTING, INC.**

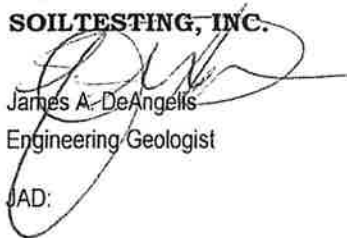
  
James A. DeAngelis  
Engineering Geologist

JAD:

THIS PROPOSAL IS UNDERSTOOD AND ACCEPTED:

Owner or Owners Representative (\*) (Please sign and print name.)  
Jacqueline Annabi, Supervisor, Town of Putnam Valley  
Billing Address/email: Town of Putnam Valley  
265 Oscawana Lake Road  
Putnam Valley, NY 10579

EMAIL(REQUIRED): jannabi@putnamvalley.gov  
Telephone Number: 845-526-2121 Date: April, 2024



(\*) Confirms above statement is correct.

Re: New Hill Road Bridge Replacement  
Putnam Valley NY

**Certificate of Insurance Requirements for this project:**

Certificate Holder (name, address, phone email):

\_\_\_\_\_  
\_\_\_\_\_

Additional Insured:

\_\_\_\_\_  
\_\_\_\_\_

*Please fill in the above requirements for your project. Allow 24-48 hours for insurer to issue COI from receipt of above information*

*Note: failure to complete insurance certificate requirements will result in a default COI being issued with addressee as certificate owner as well as additional insured.*

**Drilling Services Sales Tax Status:**

Please mark the appropriate box below for Sales tax purposes, return this sheet with your signed proposal.

|                                     | <u>Exempt</u>            | <u>Subject to<br/>Sales Tax</u> |
|-------------------------------------|--------------------------|---------------------------------|
| <b><u>DRILLING LABOR</u></b>        |                          |                                 |
| Tax Exempt Entity                   | <input type="checkbox"/> |                                 |
| Municipal                           | <input type="checkbox"/> |                                 |
| Residential                         | <input type="checkbox"/> |                                 |
| Commercial - New Construction       | <input type="checkbox"/> |                                 |
| Industrial - New Construction       | <input type="checkbox"/> |                                 |
| Income Producing - New Construction | <input type="checkbox"/> |                                 |
| Commercial - Existing               | <input type="checkbox"/> | <input type="checkbox"/>        |
| Industrial - Existing               | <input type="checkbox"/> | <input type="checkbox"/>        |
| Income Producing - Existing         | <input type="checkbox"/> | <input type="checkbox"/>        |

Thank you,

**SOILTESTING, INC.**

Soiltesting Inc. will not discriminate or permit discrimination against any person or group of persons on the grounds of race, color, religious creed, age, marital status, national origin, ancestry, sex, gender identity or expression, intellectual disability, mental disability or physical disability, including, but not limited to, blindness, unless it is shown by such contractor that such disability prevents performance of the work involved, in any manner prohibited by the laws of the United States or of the state of Connecticut; and the contractor further agrees to take affirmative action to insure that applicants with job-related qualifications are employed and that employees are treated when employed without regard to their race, color, religious creed, age, marital status, national origin, ancestry, sex, gender identity or expression, intellectual disability, mental disability or physical disability, including, but not limited to, blindness, unless it is shown by such contractor that such disability prevents performance of the work involved; Soiltesting Inc. is an affirmative action-equal opportunity employer.

return this page with your signed contract prior to Mobilization.







7

**JACQUELINE ANNABI**  
TOWN SUPERVISOR

---

TO: TOWN BOARD  
FROM: JACQUELINE ANNABI, TOWN SUPERVISOR  
SUBJECT: Addendum to Intermunicipal Agreement with Putnam County  
DATE: April 4, 2024

---

RESOLVE, that the Town Board approve an Addendum to the Intermunicipal Agreement with Putnam County regarding the reallocation of \$509,858.90 of the sales tax funding and County ARPA funding from the Bell Hollow Bridge Replacement Project to the Town of Putnam Valley's Park and Recreation Day Camp Project. This project includes, but is not limited to, winterizing the facility so that it may be used on a year-round basis and bringing the multi-use buildings up to current health and safety codes.

**ADDENDUM II**  
**To**  
**INTERMUNICIPAL AGREEMENT**  
**between**  
**THE COUNTY OF PUTNAM**  
**And**  
**THE TOWN OF PUTNAM VALLEY**

THIS ADDENDUM to the AGREEMENT, made by and between **THE COUNTY OF PUTNAM**, a municipal corporation of the State of New York, having an office and place of business at 40 Gleneida Avenue, Carmel, New York 10512 (hereinafter referred to as the “County”), acting by and through its Office of Consumer Affairs, and **THE TOWN OF PUTNAM VALLEY**, a municipal corporation of the State of New York, having an office and place of business at 265 Oscawana Lake Road, Putnam Valley, New York 10579 (hereinafter referred to as the “Town”).

**WITNESSETH:**

WHEREAS, the parties entered into an Agreement number 2022237 (the “Original Agreement”) on/about November 16, 2022, wherein the County allocated a total of \$1,204,284.00 of ARPA and County sales tax funds to the Town to assist with the completion of vital projects in the Town, as more fully described in the Original Agreement; and

WHEREAS, the parties thereafter executed an addendum to the Original Agreement on/about April 11, 2023 (hereinafter referred to as the “First Addendum”) reallocating the funding originally approved for a water and sewer project pursuant to Resolutions #133 & #134 of 2022 be modified to provide ARPA funding of \$602,124.00 to the Wenonah Road Stormwater Project and that the sales tax funding of \$602,124.00 be reallocated to the Bell Hollow Bridge

Replacement Project, as more fully described in the First Addendum; and

WHEREAS, the parties hereto wish to amend the Original Agreement; and

WHEREAS, the Town has requested that the remaining \$509,858.90 of the sales tax funding that was allocated for the Bell Hollow Bridge Replacement Project, be reallocated to the Town's current Parks and Recreation Day Camp project; and

WHEREAS, the County Executive and the Rules, Enactments & Intergovernmental Relations Committee have reviewed and approved the request; and

NOW, THEREFORE, in consideration of the terms and conditions herein contained, the parties agree as follows:

FIRST: The parties agree that paragraph "1" of the Original Agreement is hereby amended to include the following:

"As a result of a storm that undermined the Bell Hollow Road culvert, the culvert and the Bell Hollow Bridge project will be completed using funds from FEMA. The remaining \$509,858.90 of sales tax funding allocated to that project will now be reallocated to the Town's Parks and Recreation Day Camp project. The Town's Parks and Recreation Day Camp project includes but is not limited to winterizing the facility so that it can be used on a year-round basis and bringing the multi-use buildings up to current health and safety codes."

SECOND: In the event the terms and conditions of this Addendum conflict with any terms and conditions of the Original Agreement, First Addendum and/or any attachments thereto, the terms and conditions of this Addendum shall prevail.

THIRD: All other terms and conditions of the Original Agreement shall remain in full force and effect.

IN WITNESS WHEREOF, the Parties have executed this Agreement in Carmel, New York  
on the date hereinabove set forth.

**READ & APPROVED:**

\_\_\_\_\_  
Date: \_\_\_\_\_  
C. Compton Spain  
County Attorney

\_\_\_\_\_  
Date: \_\_\_\_\_  
Mat Bruno Sr.  
Risk Manager

\_\_\_\_\_  
Date: \_\_\_\_\_  
Michael J. Lewis  
Commissioner of Finance

**THE COUNTY OF PUTNAM:**

\_\_\_\_\_  
Date: \_\_\_\_\_  
Kevin M. Byrne  
County Executive

**THE TOWN OF PUTNAM VALLEY**  
265 Oscawana Lake Road  
Putnam Valley, New York 10579

\_\_\_\_\_  
Date: \_\_\_\_\_  
Jacqueline Annabi, Supervisor



8a

**TOWN OF PUTNAM VALLEY  
DISTRICTS**

**To:** Putnam Valley Town Board  
**From:** Karen Kroboth, District Clerk   
**Date:** 3/15/2024  
**Re:** Brookdale Gardens Spring Cleanup 2024

---

I formally request that the Town Board accept the proposal from Landwork Contractors for the spring cleanup of Brookdale Gardens. The cost is not to exceed \$1,000 and will be covered by the district.



*144 Buckshollow Road  
Mahopac, NY 10541  
(914) 479-2537/Fax: (914) 293-0094  
www.landworkcontractors.com*

**Proposal to:** Town of Putnam Valley  
**Property address:** 508 Lake Shore Road Boat Launch  
**Contact Information:** Karen Kroboth  
**Proposal dated:** March 19, 2024

Landwork Contractors, Inc. submits its proposal to include all labor, material, equipment and clean up necessary to complete the following scope of work:

1. Install the knocked over post in a new concrete footing.

The total cost for the above scope of work is \$350.00.

I look forward to working with you on this project. If you have any questions or concerns, please don't hesitate to contact me.

Regards,

*Joe Ruggiero*

President, Landwork Contractors, Inc.  
Cell: (914) 646-4846

86

TOWN OF PUTNAM VALLEY  
DISTRICTS

**To:** Putnam Valley Town Board  
**From:** Karen Kroboth, District Clerk   
**Date:** 3/25/2024  
**Re:** Request to waive the Building Department permit fees for the Wildwood Knolls Water Tank and Shed Demolition

---

I formally request the Town Board waive the Demolition permit application fee for the disposal of the Wildwood Knolls building and water tank. Tax Map # 62.15-1-53



PERMIT # \_\_\_\_\_

TOWN OF PUTNAM VALLEY  
DEMOLITION PERMIT APPLICATION

OWNER Town of Putnam Valley T.M.# 62.15-1-53

MAILING ADDRESS 265 Oscawana Lake Rd PHONE # 845-526-2160

LOCATION OF PROPERTY Wildwood Knolls NEAREST INTERSECTION Tinker Hill Rd

SUBDIVISION \_\_\_\_\_ LOT# \_\_\_\_\_

ZONING \_\_\_\_\_ SIZE OF LOT (SQ.FT.) \_\_\_\_\_ HEIGHT \_\_\_\_\_

DESCRIPTION OF DEMOLITION Disposal of Building & Water Tank

I, Michael A Maiuzzo, do hereby agree that the Building Code will be complied with whether the same is specified or not; as well as the Sanitary Code, Plumbing Code and any other Law, rule or regulation affecting said structure of building. The Inspector shall have the right to enter any premises during the daytime, at reasonable hours, in the course of his duty.

**All work shall be performed in accordance with the construction documents submitted and accepted as part of this application, unless changes to those documents have been approved by the Code Enforcement Officer responsible for enforcement of the code.**

**I, the owner, will be responsible for any and all outstanding Town charges including town consultant fees, associated with this permit and payable to the Town of Putnam Valley.**

(INITIAL) MAM

**Temporary sanitary facilities must be supplied until permanent sanitary facilities are operational per Section 311 of the N.Y.S. Plumbing Code. A copy of the receipt for the portable sanitary facilities or a written acknowledgement from owner that the sanitary facilities are available for use in the existing structure during construction is being done under this permit. (INITIAL) MAM**

DATE: March 25, 2024

Mike's Blue Wheel Service Inc  
(Owner or Agent)

I find plot plan to conform to the Zoning Ordinances of the Town of Putnam Valley and hereby approve same; subject to further approval and compliance with the requirements of the State Building Code and the Sanitary Code of this Town, Plumbing Code, as well as any other law, rule or regulations of the State, County, Town or Bureau or Department hereof.

DATE: 3/22/2024

  
BUILDING AND ZONING INSPECTOR

AMOUNT PAID: \_\_\_\_\_

RESIDENTIAL -- \$100  
COMMERCIAL -- \$500

8c

TOWN OF PUTNAM VALLEY  
DISTRICTS

**To:** Putnam Valley Town Board  
**From:** Karen Kroboth, District Clerk *KK*  
**Date:** 3/25/2024  
**Re:** Request to waive all fees for the LP Carraras Beach drainage project

→ permits

---

I formally request the Town Board waive any and all wetlands and building fees associated with the drainage project at Lake Peekskill's Carraras Beach. Tax Map # 83.81-2-2.

## TOWN OF PUTNAM VALLEY BUILDING DEPARTMENT WETLAND FEES AND ATTACHMENTS

### 1. Wetland Screening:

Attachments: Two Copies: Plot plan (with sketch of proposed improvements)  
Fees: \$100.00 plus \$10.00 for each acre over five acres.

Fee is to be paid with one check made payable to the Town of Putnam Valley and delivered to the Town Building Inspector.

### 2: Wetland Permits:

#### Wetland Permit Waivers:

Attachments: Original and 2 copies of application  
2 copies of deed  
2 copies of current survey and drawing showing project  
Fee: \$ 50.00: Processing  
\$200.00: Permit Review or  
\$100.00 (IF SCREENING HAS BEEN DONE)  
\$500.00: Escrow

#### Planning Board Wetland Permits:

Attachments: See Planning Board Requirements  
Fees: \$ 50.00: Processing  
\$200.00: Permit Review OR  
\$100.00 (IF SCREENING HAS BEEN DONE)  
\$1,000.00 Escrow

Fees are to be paid with three separate checks made payable to the Town of Putnam Valley and delivered to the Town Building Inspector. Note: Additional escrow fees may be needed as determined by the Wetland Inspector.

### 3. Wetland delineations and verifications:

Attachments: Signed request form  
Survey of property  
Fees: Found on Screening/Delineation/Verification Form

Note: As part of your application process, the Town may require either a wetland delineation or verification. Wetland delineations may be conducted by the Town Wetland Inspector or a wetland consultant of your choice. Please note however, that the delineation of an outside consultant will require verification by the Town Wetland Inspector. The Town fees are quoted under the Wetland Screening Section on this form and are valid for a period of two years. Town wetland delineations and verifications are valid for two years or as determined by the Approval Authority. A new delineation may be required at anytime at the discretion of the Town Wetland Permit Approval Authority.

Upon completion of project with written request by owner, and payment of final bill received from wetland inspector any escrow remaining will be released.

REV. 5/9/19

TM #: 83.81-2-2

## TOWN OF PUTNAM VALLEY BUILDING DEPARTMENT WETLANDS APPLICATION

WETLAND PERMIT APPLICATION:  Permit Waiver  Planning

The undersigned owner(s) \_\_\_\_\_ hereby apply (applies) for permit in accordance with the "Freshwater Wetlands, Watercourses and Water Bodies Ordinance", Chapter 144 of the Code of the Town of Putnam Valley.

Check One:  Application to Remedy Violation WT #: \_\_\_\_\_

Site Alteration Permit Parcel Size: \_\_\_\_\_

Location: 221 Lake Dr. Lake Peekskill (Carraras)

Violation Issued On: \_\_\_\_\_ Zoning: \_\_\_\_\_

Proposed Project: \_\_\_\_\_

Name of Nearest Intersection: \_\_\_\_\_

Name of owner(s) if different than applicant(s) LP ID

Number of buildings or structures, if any: \_\_\_\_\_

Name: Town of PV, LP ID (Owner, Contract Vendee, Agent)

Address: 265 Oscawana Lake Rd.

Telephone: 845-526-2121

Date: 3/25/24 Applicant: \_\_\_\_\_

### Office Use Only:

Is there presently an application before a local agency: Explain \_\_\_\_\_

Fee submitted on: \_\_\_\_\_

Interested party letter \_\_\_\_\_ (date)

Refer to: Wetland Inspector \_\_\_\_\_ Planning Board: \_\_\_\_\_ ZBA \_\_\_\_\_ Bldg: \_\_\_\_\_



|     |      |      |           |
|-----|------|------|-----------|
| NO. | REV. | DATE | REVISIONS |
|     |      |      |           |
|     |      |      |           |
|     |      |      |           |

DESIGNED BY: J. ROBERT FOLCHETTI & ASSOCIATES, I.L.C.  
 DRAWN BY: J.P.  
 CHECKED BY: J.A.

TOWN OF PUTNAM VALLEY  
 PUTNAM COUNTY, NEW YORK  
**CARRARA'S BEACH**  
 STORMWATER COLLECTION SYSTEM REHABILITATION

TYPICAL DETAILS - I  
 SCALE: 1/8" = 1'-0"

DATE: OCTOBER 2023  
 G SHEET 2 OF 3  
 DWG. NO. JRF1

### PRE-CAST CONCRETE TRENCH DRAIN

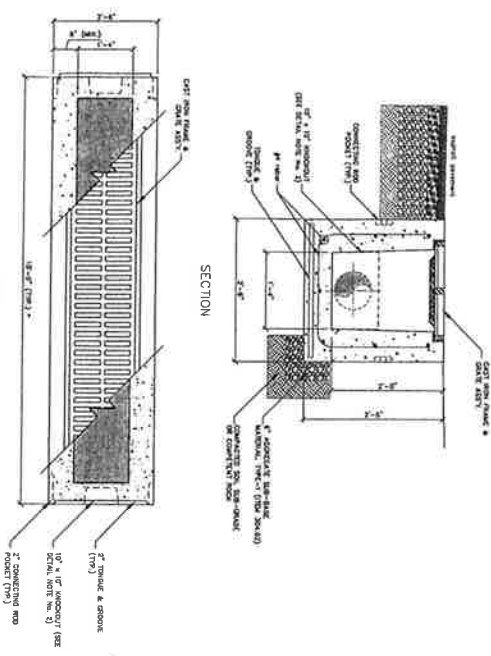

**TECHNICAL DETAIL DESIGN NOTES:**

- SEE STANDARD SPECIFICATIONS FOR ROADWAY AND AIRPORTS FOR PRECAST CONCRETE TRENCH DRAINS.
- CONCRETE SHALL BE CAST IN PLACE OR PRECAST AND SHALL BE CONSTRUCTED TO MEET THE REQUIREMENTS OF SECTION 202.01.
- CONCRETE SHALL BE CAST IN PLACE OR PRECAST AND SHALL BE CONSTRUCTED TO MEET THE REQUIREMENTS OF SECTION 202.01.
- CONCRETE SHALL BE CAST IN PLACE OR PRECAST AND SHALL BE CONSTRUCTED TO MEET THE REQUIREMENTS OF SECTION 202.01.
- CONCRETE SHALL BE CAST IN PLACE OR PRECAST AND SHALL BE CONSTRUCTED TO MEET THE REQUIREMENTS OF SECTION 202.01.
- CONCRETE SHALL BE CAST IN PLACE OR PRECAST AND SHALL BE CONSTRUCTED TO MEET THE REQUIREMENTS OF SECTION 202.01.
- CONCRETE SHALL BE CAST IN PLACE OR PRECAST AND SHALL BE CONSTRUCTED TO MEET THE REQUIREMENTS OF SECTION 202.01.
- CONCRETE SHALL BE CAST IN PLACE OR PRECAST AND SHALL BE CONSTRUCTED TO MEET THE REQUIREMENTS OF SECTION 202.01.
- CONCRETE SHALL BE CAST IN PLACE OR PRECAST AND SHALL BE CONSTRUCTED TO MEET THE REQUIREMENTS OF SECTION 202.01.
- CONCRETE SHALL BE CAST IN PLACE OR PRECAST AND SHALL BE CONSTRUCTED TO MEET THE REQUIREMENTS OF SECTION 202.01.

### HYDRODYNAMIC SEPARATOR

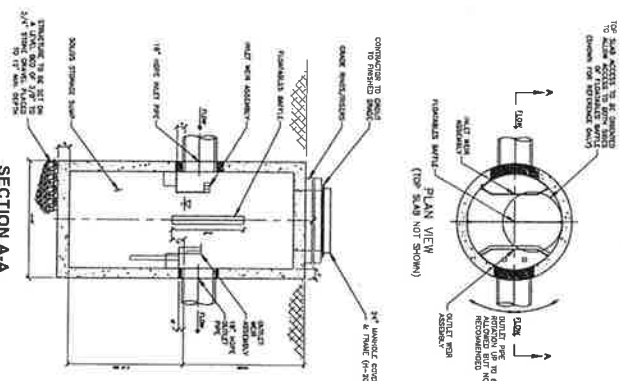

**PRECAST CONCRETE NOTES:**

- CONCRETE SHALL BE CAST IN PLACE OR PRECAST AND SHALL BE CONSTRUCTED TO MEET THE REQUIREMENTS OF SECTION 202.01.
- CONCRETE SHALL BE CAST IN PLACE OR PRECAST AND SHALL BE CONSTRUCTED TO MEET THE REQUIREMENTS OF SECTION 202.01.
- CONCRETE SHALL BE CAST IN PLACE OR PRECAST AND SHALL BE CONSTRUCTED TO MEET THE REQUIREMENTS OF SECTION 202.01.
- CONCRETE SHALL BE CAST IN PLACE OR PRECAST AND SHALL BE CONSTRUCTED TO MEET THE REQUIREMENTS OF SECTION 202.01.
- CONCRETE SHALL BE CAST IN PLACE OR PRECAST AND SHALL BE CONSTRUCTED TO MEET THE REQUIREMENTS OF SECTION 202.01.
- CONCRETE SHALL BE CAST IN PLACE OR PRECAST AND SHALL BE CONSTRUCTED TO MEET THE REQUIREMENTS OF SECTION 202.01.
- CONCRETE SHALL BE CAST IN PLACE OR PRECAST AND SHALL BE CONSTRUCTED TO MEET THE REQUIREMENTS OF SECTION 202.01.
- CONCRETE SHALL BE CAST IN PLACE OR PRECAST AND SHALL BE CONSTRUCTED TO MEET THE REQUIREMENTS OF SECTION 202.01.
- CONCRETE SHALL BE CAST IN PLACE OR PRECAST AND SHALL BE CONSTRUCTED TO MEET THE REQUIREMENTS OF SECTION 202.01.
- CONCRETE SHALL BE CAST IN PLACE OR PRECAST AND SHALL BE CONSTRUCTED TO MEET THE REQUIREMENTS OF SECTION 202.01.

### STORMWATER CONVEYANCE PIPE EMBEDMENT

| MATERIAL | THICKNESS (IN) | CONSTRUCTION     |
|----------|----------------|------------------|
| CONCRETE | 6"             | CAST IN PLACE    |
| PIPE     | 6"             | PRECAST CONCRETE |
| PIPE     | 6"             | PRECAST CONCRETE |
| PIPE     | 6"             | PRECAST CONCRETE |
| PIPE     | 6"             | PRECAST CONCRETE |
| PIPE     | 6"             | PRECAST CONCRETE |
| PIPE     | 6"             | PRECAST CONCRETE |
| PIPE     | 6"             | PRECAST CONCRETE |
| PIPE     | 6"             | PRECAST CONCRETE |
| PIPE     | 6"             | PRECAST CONCRETE |

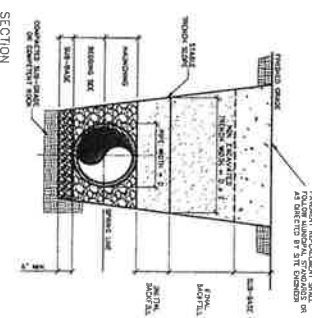

**PRECAST CONCRETE NOTES:**

- CONCRETE SHALL BE CAST IN PLACE OR PRECAST AND SHALL BE CONSTRUCTED TO MEET THE REQUIREMENTS OF SECTION 202.01.
- CONCRETE SHALL BE CAST IN PLACE OR PRECAST AND SHALL BE CONSTRUCTED TO MEET THE REQUIREMENTS OF SECTION 202.01.
- CONCRETE SHALL BE CAST IN PLACE OR PRECAST AND SHALL BE CONSTRUCTED TO MEET THE REQUIREMENTS OF SECTION 202.01.
- CONCRETE SHALL BE CAST IN PLACE OR PRECAST AND SHALL BE CONSTRUCTED TO MEET THE REQUIREMENTS OF SECTION 202.01.
- CONCRETE SHALL BE CAST IN PLACE OR PRECAST AND SHALL BE CONSTRUCTED TO MEET THE REQUIREMENTS OF SECTION 202.01.
- CONCRETE SHALL BE CAST IN PLACE OR PRECAST AND SHALL BE CONSTRUCTED TO MEET THE REQUIREMENTS OF SECTION 202.01.
- CONCRETE SHALL BE CAST IN PLACE OR PRECAST AND SHALL BE CONSTRUCTED TO MEET THE REQUIREMENTS OF SECTION 202.01.
- CONCRETE SHALL BE CAST IN PLACE OR PRECAST AND SHALL BE CONSTRUCTED TO MEET THE REQUIREMENTS OF SECTION 202.01.
- CONCRETE SHALL BE CAST IN PLACE OR PRECAST AND SHALL BE CONSTRUCTED TO MEET THE REQUIREMENTS OF SECTION 202.01.
- CONCRETE SHALL BE CAST IN PLACE OR PRECAST AND SHALL BE CONSTRUCTED TO MEET THE REQUIREMENTS OF SECTION 202.01.

### MANHOLE FRAME & COVER ASSEMBLY

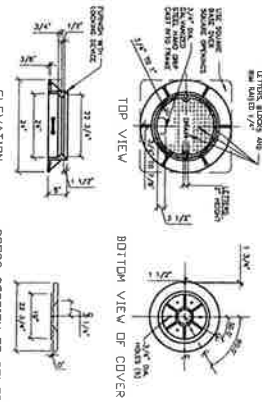

**MANHOLE FRAME & COVER ASSEMBLY NOTES:**

- CONCRETE SHALL BE CAST IN PLACE OR PRECAST AND SHALL BE CONSTRUCTED TO MEET THE REQUIREMENTS OF SECTION 202.01.
- CONCRETE SHALL BE CAST IN PLACE OR PRECAST AND SHALL BE CONSTRUCTED TO MEET THE REQUIREMENTS OF SECTION 202.01.
- CONCRETE SHALL BE CAST IN PLACE OR PRECAST AND SHALL BE CONSTRUCTED TO MEET THE REQUIREMENTS OF SECTION 202.01.
- CONCRETE SHALL BE CAST IN PLACE OR PRECAST AND SHALL BE CONSTRUCTED TO MEET THE REQUIREMENTS OF SECTION 202.01.
- CONCRETE SHALL BE CAST IN PLACE OR PRECAST AND SHALL BE CONSTRUCTED TO MEET THE REQUIREMENTS OF SECTION 202.01.
- CONCRETE SHALL BE CAST IN PLACE OR PRECAST AND SHALL BE CONSTRUCTED TO MEET THE REQUIREMENTS OF SECTION 202.01.
- CONCRETE SHALL BE CAST IN PLACE OR PRECAST AND SHALL BE CONSTRUCTED TO MEET THE REQUIREMENTS OF SECTION 202.01.
- CONCRETE SHALL BE CAST IN PLACE OR PRECAST AND SHALL BE CONSTRUCTED TO MEET THE REQUIREMENTS OF SECTION 202.01.
- CONCRETE SHALL BE CAST IN PLACE OR PRECAST AND SHALL BE CONSTRUCTED TO MEET THE REQUIREMENTS OF SECTION 202.01.
- CONCRETE SHALL BE CAST IN PLACE OR PRECAST AND SHALL BE CONSTRUCTED TO MEET THE REQUIREMENTS OF SECTION 202.01.

WARNING: IT IS A VIOLATION OF NEW YORK ESCALATOR LAW TO INSTALL AN ESCALATOR WITHOUT A PERMIT FROM THE DEPARTMENT OF LABOR. THE PERMIT SHALL BE OBTAINED FROM THE DEPARTMENT OF LABOR, 120 NASSAU ST., NEW YORK, NY 10038. FOR MORE INFORMATION, VISIT WWW.DOL.STATE.NY.US.



8d

TOWN OF PUTNAM VALLEY  
DISTRICTS

**To:** Town Board  
**From:** Karen Kroboth – District Clerk   
**Date:** 4/1/2024  
**Re:** Roaring Brook Lake Superintendent appointment 2024

---

I formally request the Town Board appoint Brian Mansfield as the Roaring Brook Lake Superintendent for the 2024 season at a set salary of \$4,000.00, with no benefits. This position will run from mid-May through mid-September.



8e

TOWN OF PUTNAM VALLEY  
DISTRICTS

**To:** Putnam Valley Town Board  
**From:** Karen Kroboth, District Clerk *(KK)*  
**Date:** 3/27/2024  
**Re:** Award the District Property Grass Cutting Bid 2024

---

I formally request that the Town Board accept the lowest bid for the 2024 District Property Grass Cutting, received from Landwork Contractors, Inc. 144 Buckshollow Rd, Mahopac, NY 1054. There was only one bid received.

**The total lump sum bid is \$14,850.00 for the 2024 season.**

Bid opening minutes are attached for your review.



# TOWN OF PUTNAM VALLEY

## Bid Opening Minutes District Grass Cutting 2024 March 27, 2024 @ 2:30 pm

.....

In attendance: Kathy Diomende – Town Clerk, Karen Kroboth – District Clerk and Julie Rinaldi –Deputy Tax Receiver

**One bid was received for the District Grass Cutting Bid 2024 from Landwork Contractors, Inc. 144 Buckshollow Rd, Mahopac, NY 10541. The total lump sum bid from Landwork was \$14,850.**

Included in the bid was the following:

- Non Collusion Affidavit
- Professional References
- Proposal
- Specifications for Grass Cutting
- Certification Form Note and Lump Sum Cost
- References
- Section 103-a and 103-d of the General Municipal Law

---

### Grass Cutting Bid 2023 Comparison

|                                                     | Landwork |
|-----------------------------------------------------|----------|
| Barger Pond District                                | 550.00   |
| Brookdale Gardens                                   | 550.00   |
| Glenmar Gardens                                     | 2,000.00 |
| Hilltop District Beach                              | 1,700.00 |
| Abele Park                                          | 900.00   |
| Lookout Manor                                       | 700.00   |
| Northview                                           | 700.00   |
| Wildwood Knolls                                     | 800.00   |
| Total #1                                            | 7,900.00 |
| Roaring Brook Lake District Properties 2x/month cut | 1,800.00 |
| Total #2                                            | 1,800.00 |
| Roaring Brook Lake 1x/month cut                     | 2,700.00 |
| Total #3                                            | 2,700.00 |
| Drainage and District Properties                    | 2,450.00 |
| Total #4                                            | 2,450.00 |

---

**LUMP SUM TOTAL: 14,850.00**

---

8f

TOWN OF PUTNAM VALLEY  
DISTRICTS

**To:** Putnam Valley Town Board  
**From:** Karen Kroboth, District Clerk   
**Date:** 3/29/2024  
**Re:** Approve emergency repair at LPID Community Center

---

I formally request the Town Board authorize the repair/replacement of the Lake Peekskill Community Center well pump. This is an emergency repair as there is currently no water in the community center. The repair will be done by J. Meister pumps and plumbing.

The cost of the repair is not to exceed \$3,000 and will be covered by the district.

89

**TOWN OF PUTNAM VALLEY**

**To:** Town Board Members

**From:** Karen Kroboth – District Clerk

*KK*

**Date:** 4/1/2024

**Re:** 2024 Wildwood Knolls Facilities Warrant

---

I formally request that the Town Board adopt the Wildwood Knolls Facilities Warrant for the year 2024.

Facility users – 19 families @ \$200 each

Total: \$3,800

8h

**TOWN OF PUTNAM VALLEY  
DISTRICTS**

**To:** Putnam Valley Town Board

**From:** Karen Kroboth, District Clerk 

**Date:** 4/8/2024

**Re:** Appoint LPID temporary help

---

I formally request the Town Board appoint Alex Jemty as a temporary Lake Peekskill Laborer during bulk pick up. Alex's rate is \$16.00 per hour with no benefits. The appointment will begin April 15<sup>th</sup> and end on April 26<sup>th</sup>, 2024. The cost will be covered by the district.

9a

Shawn Keeler  
Highway Superintendent  
SKEELER@PUTNAMVALLEY.COM

David Conklin  
General Foreman

Margaret Bradley  
Senior Clerk Typist

Sarah Caporale  
Part time Clerk

265 Oscawana Lake Road  
Putnam Valley, NY 10579

(845) 526-3333 phone  
(845) 526-4729 fax

Hours of operation:  
7:00 AM - 3:30 PM

## Town of Putnam Valley Highway Department

March 20, 2024

### MEMORANDUM

TO: Jacquie Annabi  
Members of the Town Board

FROM: Shawn M. Keeler

RE: Surplus equipment

The following vehicles and equipment are declared surplus and will be auctioned.

2003 International 7400, VIN# 1HTWEAAR23J071748 – Highway Truck 40

2010 International 4300, VIN# 1HTMZSKN9AJ223681 – Highway Truck 41

2009 Dodge 3500, VIN# 3D6WH46LX9G524268 – Lake Peekskill Improvement District

Miscellaneous Power Equipment (Used and broken saws, trimmers, blowers, etc.)

Rayco Stump Grinder, Serial #3110811061, Highway Equipment # E-11

Stone Diaphragm trash pump 3” – Model DIA-5B, Serial # 0311012

Sincerely,

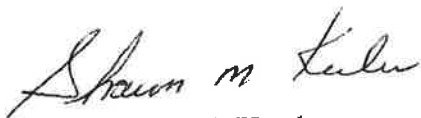

Shawn M. Keeler

Shawn Keeler  
Highway Superintendent  
SKEELER@PUTNAMVALLEY.COM

265 Oscawana Lake Road  
Putnam Valley, NY 10579

96

David Conklin  
General Foreman

(845) 526-3333 phone  
(845) 526-4729 fax

Margaret Bradley  
Senior Clerk Typist

Hours of operation:  
7:00 AM - 3:30 PM

Sarah Caporale  
Part time Clerk

## Town of Putnam Valley Highway Department

DATE: April 8, 2024

### MEMORANDUM

TO: Jacquie Annabi  
Members of the Town Board

FROM: Shawn M. Keeler

RE: New Equipment Purchase

In 2023, I ordered an International 7500 Series Dump Truck from Arkel Motors. I have been informed that Arkel has been backed up with orders and cannot fulfill the order at this time. \$250,000.00 was designated from our BAN for this purchase.

I am seeking permission to reallocate these funds to purchase a 2024 John Deere 624 Wheel Loader for \$210,000.00. This will replace our 2014 624 Loader, that we will be trading in.

Sincerely,

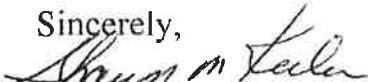
  
Shawn M. Keeler

10

# Memo

**To:** Town Board  
**From:** Theresa Orlando  
**CC:** Elaine McGinty  
**Date:** 4/2/2024  
**Re:** When I Work Agreement

---

## **Town Board Members**

Please authorize Town Supervisor Jacquie Annabi to sign the When I Work agreement, for an app used with our town lifeguards for the upcoming summer season. It is utilized from beginning of May to Labor Day. Please see attached agreement, Thank you.



## Quote

Putnam Valley Parks & Recreation  
 265 Oscawana Lake Road  
 Putnam Valley NY 10579  
 United States

Date 3/27/2024

Proposal # DP4393

Expiration Date 6/9/2024

Sales Rep

Acct. No. 3284629

Scheduling Basic + Attendance

When I Work Scheduling Basic w/Attendance

702.00

Annual Plan Effective: 6/10/24 - 6/9/25  
 50 Users

\*\*\*Seasonal pricing based on 5 months of usage

Annual plan will be activated upon receipt of signed quote or purchase order.

Account Holder: Theresa Orlando - torlando@putnamvalley.com

**Total**

**\$702.00**

Unless there is an executed, written agreement between When I Work and the purchaser, then signing the quote, issuing a PO, or accessing and using the service confirms review, understanding and acceptance of the Terms of Service ([wheniwork.com/terms](http://wheniwork.com/terms)) and Privacy Policy ([wheniwork.com/privacy](http://wheniwork.com/privacy)). The terms and conditions of any Purchase Order issued with respect to this purchase are superseded by When I Work's Terms of Service and Privacy Policy.

**Payment info:**

1. Payment options: Check, wire/ACH or credit card from within app.
2. If paying via check or wire, customer will be invoiced following signing of this quote.
3. Payment is due upon receipt of invoice.
4. Please return signed quote for processing.
5. If applicable, tax will be calculated at the time of invoicing in the following states: AZ, CT, DC, HI, IA, MA, MD, NM, NY, PA, RI, SC, SD, TN, TX, UT, WA & WV. If tax exempt please supply exemption certificate.

**Reviewed and Accepted by:**  
 (Authorized to sign on behalf of purchaser)

Signature: \_\_\_\_\_  
 Printed name: \_\_\_\_\_  
 Title: \_\_\_\_\_  
 Date: \_\_\_\_\_



11

**JACQUELINE ANNABI**  
TOWN SUPERVISOR

---

TO: TOWN BOARD  
FROM: JACQUELINE ANNABI, TOWN SUPERVISOR  
SUBJECT: TelVue Corporation  
DATE: April 4, 2024

---

RESOLVE, that the Town Board approve and accept the proposal from TelVue Corporation for necessary community media department equipment, totaling \$4,197.50. This cost will be covered by ARPA funds. There will be an additional annual \$495.00 service licensing fee going forward, which includes hardware warranty, technical support, software updates and access to cloud-based InfoVue signage application. This annual licensing fee will be included in our budget going forward.



WE SHARE YOUR VISION™

TELVue CORPORATION  
16000 HORIZON WAY, SUITE 100  
MT. LAUREL, NJ 08054

Quote#: Q-017821  
Quote Issued: 8/16/2023  
Quote Expiration: 9/27/2024

| TelVue Quotation – Confidential                                                                                                                                                                                                        | TelVue Contact Information                                                                                                                                                                                                                                           |
|----------------------------------------------------------------------------------------------------------------------------------------------------------------------------------------------------------------------------------------|----------------------------------------------------------------------------------------------------------------------------------------------------------------------------------------------------------------------------------------------------------------------|
| <p>Prepared for:<br/>Kelvin Guevara<br/>Putnam Valley Community TV - PVNY<br/>Community Media<br/>kguevara@putnamvalley.gov<br/>845-743-5260</p> <p>Ship to address:<br/>265 Oscawana Lake Road<br/>Putnam Valley, NY 10579<br/>US</p> | <p>Prepared by:<br/>Charles Paige<br/>TelVue Corporation<br/>Email: cpaige@telvue.com<br/>Phone: (800) 885-8886 x122<br/>Fax: (856) 866-7411</p> <p>Please use Fax No. to submit signed quote, or email <a href="mailto:orders@telvue.com">orders@telvue.com</a></p> |

| Special Terms                                                                                                                                                                                                                                                    |
|------------------------------------------------------------------------------------------------------------------------------------------------------------------------------------------------------------------------------------------------------------------|
| <p>*Prior to signing the quote in indication of your acceptance as a purchase order, please confirm the billing contact information and shipping information above.</p> <p>*If you have any questions please contact your TelVue contact (identified above).</p> |

| Customer Acceptance                                                                                                                                                                                                                                                                                                                                                |
|--------------------------------------------------------------------------------------------------------------------------------------------------------------------------------------------------------------------------------------------------------------------------------------------------------------------------------------------------------------------|
| <p>This quote is good for 30 days from date of issue or until any expiration date stated in the special terms field.</p> <p>By signing below, customer accepts quote as purchase order on the above terms:</p> <p>Printed Name: <u>Jacqueline Annabi</u> Title: <u>Town Supervisor, Town of Putnam Valley</u></p> <p>Signature: _____ Date: <u>April</u>, 2024</p> |

Thank you for your business. The following page contains a quote for TelVue products and services.



TELVue CORPORATION  
16000 HORIZON WAY, SUITE 100  
MT. LAUREL, NJ 08054

Quote#: Q-017821  
Quote Issued: 8/16/2023  
Quote Expiration: 9/27/2024

WE SHARE YOUR VISION™

| Hardware    |                  |                                                                                                                                                                                                                                          |          |            |          |             |                |                |
|-------------|------------------|------------------------------------------------------------------------------------------------------------------------------------------------------------------------------------------------------------------------------------------|----------|------------|----------|-------------|----------------|----------------|
| Qty.        | Item Name        | Description                                                                                                                                                                                                                              | TC Elig. | List Price | Discount | Sales Price | Unit Net Price | Ext. Net Price |
| InfoVue     |                  |                                                                                                                                                                                                                                          |          |            |          |             |                |                |
| 1.00        | InfoVue Standard | Standard InfoVue Digital Signage player, 1RU rack mount, 120GB SSD storage, HDMI output up to 1080p. InfoVue Service License required for access to cloud InfoVue CMS and Weather. Multi-user, Multi-zone, SD/HD, data feed integration. |          | \$1,950.00 | 15.00%   | \$1,950.00  | \$1,657.50     | \$1,657.50     |
| Third-Party |                  |                                                                                                                                                                                                                                          |          |            |          |             |                |                |
| 1.00        | CUSTOM-3P EQUIP  | Blonder Tongue HDE-CSV-QAM Component/HD-SDI/HDMI/VGA/Composite to QAM/ASI/IP MPEG-2 HD Encoder                                                                                                                                           |          | \$0.00     |          | \$1,995.00  | \$1,995.00     | \$1,995.00     |
|             |                  |                                                                                                                                                                                                                                          |          |            |          |             |                | \$3,652.50     |

| Shipping & Handling |              |                        |          |            |             |                |                |         |
|---------------------|--------------|------------------------|----------|------------|-------------|----------------|----------------|---------|
| Qty.                | Item Name    | Description            | TC Elig. | List Price | Sales Price | Unit Net Price | Ext. Net Price |         |
| InfoVue             |              |                        |          |            |             |                |                |         |
| 1.00                | InfoVue Ship | InfoVue Shipping./TPCL |          | \$50.00    | \$50.00     | \$50.00        | \$50.00        |         |
|                     |              |                        |          |            |             |                | Sub-total      | \$50.00 |

| General Services |                         |                                                                                                                                                                                                                                                         |          |            |             |                |                |          |
|------------------|-------------------------|---------------------------------------------------------------------------------------------------------------------------------------------------------------------------------------------------------------------------------------------------------|----------|------------|-------------|----------------|----------------|----------|
| Qty.             | Item Name               | Description                                                                                                                                                                                                                                             | TC Elig. | List Price | Sales Price | Unit Net Price | Ext. Net Price |          |
| Cloud Svcs       |                         |                                                                                                                                                                                                                                                         |          |            |             |                |                |          |
| 1.00             | InfoVue Service License | InfoVue Service License - Includes hardware warranty, technical support, software updates & access to cloud-based InfoVue signage application. Ongoing InfoVue Service Licensing is required for access to the InfoVue services. Billed Annually. /TPCL |          | \$495.00   | \$495.00    | \$495.00       | \$495.00       |          |
|                  |                         |                                                                                                                                                                                                                                                         |          |            |             |                | Sub-total      | \$495.00 |

Grand Total \$4,197.50

A finance / late fee of 1% per month will be added to an unpaid balance each month thereafter. Purchases of equipment outside of the United States require advance payment or letter of credit.



WE SHARE YOUR VISION™

TELVUE CORPORATION  
16000 HORIZON WAY, SUITE 100  
MT. LAUREL, NJ 08054

Quote#: Q-017821  
Quote Issued: 8/16/2023  
Quote Expiration: 9/27/2024

Net 30 Days. 2% cash/1% net 15. Credit cards are accepted.



WE SHARE YOUR VISION™

TELVue CORPORATION  
16000 HORIZON WAY, SUITE 100  
MT. LAUREL, NJ 08054

Quote#: Q-017821  
Quote Issued: 8/16/2023  
Quote Expiration: 9/27/2024

**Noted Service Options:**

TelVue Care™ is quoted as 15% of the value at sale of TelVue Care™ eligible equipment for year 2 coverage, declining (straight line) to 7.5% in the 5th year coverage if prepaid.

Year 2 TelVue Care™: 0.00  
Year 3 TelVue Care™: 0.00  
Year 4 TelVue Care™: 0.00  
Year 5 TelVue Care™: 0.00



WE SHARE YOUR VISION™

TEL VUE CORPORATION  
16000 HORIZON WAY, SUITE 100  
MT. LAUREL, NJ 08054

Quote#: Q-017821  
Quote Issued: 8/16/2023  
Quote Expiration: 9/27/2024

## TelVue Terms & Conditions

The products ("Products") and services ("Services") provided by TelVue Corporation (TEL VUE) to you ("Customer") are subject to the following terms and conditions ("Terms and Conditions"). By placing an order with TEL VUE, Customer agrees to be bound by these terms and conditions. These Terms and Conditions shall apply to all quotations and offers made and accepted by TEL VUE. The Terms and Conditions contained herein are subject to change at any time by TEL VUE in its sole discretion and without notice to any potential purchaser of the TelVue's products and services. No purchase order submitted under these quoted Terms and Conditions shall be deemed to create a binding contract until such time as TelVue accepts such purchase order. TelVue reserve the right to decline any purchase order based on this quote at its sole discretion. Customer agrees that these Terms and Conditions may in some instances conflict with some of the terms and conditions affixed to the purchase order or procurement document issued by the Customer. In that case, the Terms and Conditions contained herein shall govern and acceptance of Customer's order is expressly conditioned upon Customer's acceptance of these Terms and Conditions whether the Customer accepts the Terms and Conditions by written acknowledgment, implication, or acceptance and payment of Products or Services purchased. TEL VUE's failure to object to provisions contained in any communication from Customer to the contrary shall not be deemed a waiver of the provisions of these Terms and Conditions. TEL VUE will use commercially reasonable efforts to ship Products to Customer's address listed on the TEL VUE Quote Form, and to provide Services to Customer's authorized users in accordance with the scheduled date specified by TEL VUE. Customer acknowledges and agrees that delivery schedules are subject to change. TEL VUE will notify Customer of any anticipated delay of thirty (30) or more days in delivery of the Products or Services purchased. Products are delivered F.O.B. TEL VUE shipping point. Customer shall pay all shipping charges, including without limitation, transportation charges and insurance premiums, and shall be responsible for all taxes, duties and other government assessments. Customer shall pay TEL VUE for any product or service fee (collectively, "FEES") set forth on TEL VUE's Quote Form. Payment shall be made in U.S. dollars in the U.S. where Customer has established credit, and the terms of payment will be "NET 30" -- thirty (30) days from invoice date unless otherwise indicated on the invoice. Any FEES not paid by Customer when due shall bear interest until paid at a rate of one and one-half percent (1.5%) per month (eighteen percent (18%) per annum), or the maximum rate permitted by law, whichever is less. Customer shall be responsible for the costs, including without limitation, attorneys' fees and court costs, incurred by TEL VUE in connection with TEL VUE's collection of any past-due FEES. Customer shall bear and be solely responsible for the payment of all taxes levied or assessed in connection with the Products and Services, if any, including without limitation, all sales, use, rental receipt, personal property, import and monthly or other taxes (but excluding taxes based solely upon TEL VUE's income). In addition to any other remedy available to it, TEL VUE may suspend or terminate the Services, in whole or in part, upon Customer's failure to timely pay the FEES without incurring any liability to Customer or others associated with Customer. All FEES paid and charges made prior to any termination as provided herein are nonrefundable. Termination of the Services shall not release Customer from any obligation to pay accrued charges on FEES. TEL VUE may increase its FEES for any TEL VUE-provided content and third-party software to the extent that its licensors raise their fees to TEL VUE upon not less than thirty (30) days prior written notice to the Customer. If the increases exceed ten percent (10%) of the then current FEES, Customer may choose to delete the TEL VUE-provided content or third-party software, as applicable. TEL VUE reserves the right to begin charging Services FEES if the Services are not launched by Customer within one hundred twenty (120) days of the order date through no fault of TEL VUE. Customer shall comply with all export laws and restrictions and regulations of the Department of Commerce or other United States or foreign agency or authority, and shall not export, or allow the export or re-export of the Products or any Confidential Information or any direct product thereof in violation of any such restrictions, laws or regulations, or to Afghanistan, the People's Republic of China or any Group Q, S, W, Y, or Z country specified in the then current Supplement No. 1 to Section 770 of the U.S. Export Administration Regulations (or any successor supplement or regulations); Customer shall obtain and bear all expenses relating to any necessary licenses and/or exemptions with respect to the export from the U.S. of all material or items deliverable by TEL VUE to any location and shall demonstrate to TEL VUE compliance with all applicable laws and regulations prior to delivery thereof by TEL VUE. TEL VUE warrants to Customer that the Products or Services offered by TEL VUE pursuant to these Terms and Conditions shall conform to the specifications for such Products or Services mutually agreed to by the parties in writing at the time of shipment. The warranty period for hardware-based Products shall be twelve (12) months from the date of shipment. Customer's sole remedy for breach of the foregoing warranties shall be limited to Product replacement, or if replacement is inadequate, or in TEL VUE's sole discretion impractical, to refund the purchase price. TEL VUE PROVIDES THE PRODUCTS AND SERVICES "AS IS" AND MAKES NO WARRANTY THAT THE PRODUCTS OR SERVICES WILL BE UNINTERRUPTED, TIMELY, SECURE, OR ERROR FREE; NOR DOES TEL VUE MAKE ANY WARRANTY AS TO THE RESULTS THAT MAY BE OBTAINED FROM THE PRODUCTS OR SERVICES OR AS TO THE ACCURACY OR RELIABILITY OF ANY CONTENT OBTAINED THROUGH THE PRODUCTS OR SERVICES, EXCEPT AS SET FORTH HEREIN, OR IN A WRITTEN AGREEMENT BETWEEN THE PARTIES THAT EXPRESSLY AMENDS TEL VUE'S WARRANTY, AND SUBJECT TO APPLICABLE LAW, TEL VUE MAKES NO OTHER, AND EXPRESSLY DISCLAIMS ALL OTHER, REPRESENTATIONS, WARRANTIES, CONDITIONS OR COVENANTS, EITHER EXPRESS OR IMPLIED (INCLUDING WITHOUT LIMITATION, ANY EXPRESS OR IMPLIED WARRANTIES OR CONDITIONS OF FITNESS FOR A PARTICULAR PURPOSE, MERCHANTABILITY, DURABILITY, TITLE, ACCURACY OR NONINFRINGEMENT) ARISING OUT OF OR RELATED TO THE PERFORMANCE OR NONPERFORMANCE OF THE SERVICES, INCLUDING, BUT NOT LIMITED TO, ANY WARRANTY RELATING TO THIRD PARTY SERVICES. ANY WARRANTY WITH RESPECT TO THE PERFORMANCE OF ANY HARDWARE OR SOFTWARE USED IN PERFORMING



WE SHARE YOUR VISION™

TELVue CORPORATION  
16000 HORIZON WAY, SUITE 100  
MT. LAUREL, NJ 08054

Quote#: Q-017821  
Quote Issued: 8/16/2023  
Quote Expiration: 9/27/2024

SERVICES AND ANY WARRANTY CONCERNING THE RESULTS TO BE OBTAINED FROM THE SERVICES. THIS DISCLAIMER AND EXCLUSION SHALL APPLY EVEN IF THE EXPRESS WARRANTY AND LIMITED REMEDY SET FORTH HEREIN FAILS OF ITS ESSENTIAL PURPOSE. To the extent that TELVUE data is transmitted over the Internet, Customer acknowledges and agrees that TELVUE has no control over the functioning of the Internet and TELVUE makes no representations or warranties of any kind regarding the performance of the Internet.

TELVUE and Customer are independent contractors in the performance of these Terms and Conditions, and each party is solely responsible for all of its employees and agents and its labor costs and expenses arising in connection therewith. Customer is responsible for and will indemnify TELVUE from any and all claims, liabilities, damages, debts, settlements, costs, attorney's fees, expenses and liabilities of any type whatsoever that may arise in connection with the purchase and use of Products or Services and on account of Customer's activities, or those of its employees or agents, including without limitation, providing unauthorized representations or warranties (or failing to effectively disclaim all warranties and liabilities on behalf of TELVUE) to its customers or breaching any term, representation or warranty of these Terms and Conditions.

Certain TELVUE Products and Services require a full-time Internet connection for proper operation. An Internet connection may also be required for remote TELVUE support. Customer is responsible for providing Internet access that meets TELVUE's requirements. Customer shall provide TELVUE with access to Customer's technical personnel, facilities, systems, databases and information as necessary or appropriate for TELVUE to perform its obligations under these Terms and Conditions. Customer shall be solely responsible for all content supplied by Customer. Customer represents and warrants to TELVUE that such content will not violate or infringe any copyright, patent, trademark, trade secret, confidentiality or other proprietary right of any third party. License granted to Customer is for the object code version of the Products or Services and TELVUE-provided content only. Customer has no rights to the source code for the Products or Services or any TELVUE-provided content. Customer shall not permit anyone under Customer's direction or control to, reverse engineer, disassemble, de-compile or remove any identifying mark of TELVUE or its licensors from the Products, Services or any TELVUE-provided content or attempt to do so. Customer may not modify, adapt, translate or create derivative works of the Products, Services or any TELVUE-provided content without TELVUE's express written consent. The Services are licensed as a single product. TELVUE-provided content may be used only in conjunction with the Services. TELVUE shall retain all Proprietary Rights in and to the aforementioned and to any discoveries, improvements, inventions (whether or not patentable), ideas or know how that is conceived, learned, or reduced to practices by TELVUE in the course of performance under these Terms and Conditions. Both parties agree that all system designs, computer programs, data, processes, trade secrets, inventions (whether or not patentable), algorithms, know-how, and ideas and all other business, marketing, technical and financial information they obtain from the other party constitute "Confidential Information" of the disclosing party if marked as such when disclosed in writing, or if disclosed orally, designated as such within 10 days of oral disclosure. Except as expressly and unambiguously allowed under these Terms and Conditions, TELVUE and Customer agree to hold in confidence and not use or disclose the other party's Confidential Information. The receiving party shall not be obligated for any information which it can document: is in or (through no improper action or inaction by the receiving party) enters the public domain (and is readily available without substantial effort), or was rightfully in its possession or known by it prior to receipt from the disclosing party, or was rightfully disclosed to it by another person without restriction, or was independently developed by it by persons without access to such information and without use of any Confidential Information of the disclosing party, or is required to be disclosed pursuant to local or federal statutes and/or regulations. These obligations shall continue for a period of three (3) years from disclosure. TELVUE WILL NOT BE LIABLE WITH RESPECT TO OR ARISING OUT OF ANY SUBJECT MATTER OF THESE TERMS AND CONDITIONS UNDER ANY CONTRACT, NEGLIGENCE, STRICT LIABILITY OR OTHER THEORY FOR ANY AMOUNTS IN EXCESS IN THE AGGREGATE OF THE AMOUNTS PAID TO TELVUE HERE UNDER OR ANY INCIDENTAL, INDIRECT, SPECIAL, PUNITIVE OR CONSEQUENTIAL DAMAGES, INCLUDING, BUT NOT LIMITED TO, LOST OF PROFITS, BUSINESS REVENUES OR SAVINGS, LOST DATA OR COST OF PROCUREMENT OF SUBSTITUTE GOODS, TECHNOLOGY OR SERVICES. TELVUE SHALL HAVE NO LIABILITY FOR ANY FAILURE OR DELAY DUE TO MATTERS BEYOND ITS REASONABLE CONTROL. THE ENTIRE RISK ARISING OUT OF THE USE AND/OR PERFORMANCE OF THE PRODUCTS OR SERVICES REMAINS WITH CUSTOMER. IN NO EVENT SHALL TELVUE OR ITS LICENSORS OR ANY OF THEIR OFFICERS, DIRECTORS, EMPLOYEES, AGENTS OR AFFILIATES BE LIABLE FOR ANY CONSEQUENTIAL, INCIDENTAL, DIRECT, INDIRECT, SPECIAL, PUNITIVE, OR OTHER DAMAGES WHATSOEVER (INCLUDING, WITHOUT LIMITATION, DAMAGES FOR LOSS OF BUSINESS PROFITS, BUSINESS INTERRUPTION, LOSS OF BUSINESS INFORMATION, OR OTHER PECUNIARY LOSS) ARISING OUT OF USE OF OR INABILITY TO USE ANY PRODUCTS OR SERVICE, EVEN IF TELVUE HAS BEEN ADVISED OF THE POSSIBILITY OF SUCH DAMAGES OR ARE OTHERWISE FORSEEABLE. IN THE EVENT A JURISDICTION DOES NOT PERMIT THE EXCLUSION OR LIMITATION OF LIABILITY FOR CONSEQUENTIAL OR INCIDENTAL DAMAGES, THESE LIMITATIONS SHALL APPLY TO THE MAXIMUM EXTENT PERMITTED BY LAW.

TelVue Hardware Warranty and TelVue Care Extended Warranty Terms and Conditions - TelVue Corporation (TelVue) will at its option, either repair, replace or upgrade software and/or firmware on any product manufactured by TelVue which proves to be defective in materials or workmanship or fails to meet the specifications which are in effect on the date of shipment or such other specifications as may have been expressly agreed upon in writing for a period of one (1) year from the date of original purchase. With optional TelVue Care, the equipment owner can extend these terms for up to four additional years. Certain products





WE SHARE YOUR VISION™

TELVue CORPORATION  
16000 HORIZON WAY, SUITE 100  
MT. LAUREL, NJ 08054

Quote#: Q-017821  
Quote Issued: 8/16/2023  
Quote Expiration: 9/27/2024

that are not manufactured but are resold by TelVue will carry the original OEM warranty for that product. In the case of a failure, the customer will be responsible for round trip shipping costs to TelVue and up to a \$500 maximum factory repair service deductible. This warranty does not cover damage resulting from (i) use or installation other than in strict accordance with manufacturer's written instructions, (ii) disassembly or repair by someone other than the manufacturer or a manufacturer-authorized repair center, (iii) misuse, misapplication or abuse, (iv) alteration, (v) lack of reasonable care or (vi) acts of God. A \$500 reactivation fee will apply to a lapsed warranty for TelVue Care on equipment. TelVue Care is not transferrable without written permission from TelVue.

If any provision of these Terms and Conditions is held unenforceable by a court of competent jurisdiction, that provision shall be limited or eliminated to the minimum extent necessary so that the Terms and Conditions shall otherwise remain in full force and effect and enforceable. These Terms and Conditions shall be governed by and construed under the laws of the State of New Jersey and the United States without regard to the conflicts of laws provisions thereof and without regard to the United Nations Convention on Contracts for the International Sale of Goods. The parties agree that venue for any action of any kind shall be Burlington County, New Jersey. Any waiver or amendment to these Terms and Conditions shall be effective only if made in writing and signed by a representative of the respective parties, authorized to bind the parties. The prevailing party in any action to enforce these Terms and Conditions shall be entitled to recover costs and expenses, including, without limitation, attorneys' fees. Notices given under these Terms and Conditions shall be in writing and considered to be received upon the earlier of actual receipt or five (5) days after mailing if mailed postage prepaid by regular mail, or one (1) day after such notice is sent by major commercial rapid delivery courier or facsimile transmission. Any delay or failure by either party to exercise any right or remedy will not constitute a waiver of that party to thereafter enforce such rights.

INFOVUE - Terms & Conditions: InfoVue is sold under additional terms and conditions related to various optional information services available. These terms and conditions are contained on the TelVue web site. It is the responsibility of the Customer/User to review those terms and conditions and to ensure compliance with them. The terms and conditions for InfoVue can be found at:

<http://www.telvue.com/wp-content/uploads/InfoVue-End-User-Licensing-Terms-and-Conditions-2015-5-4.pdf>

The information contained in this quote is confidential and proprietary to TelVue Corporation and may not be disclosed to third parties or duplicated, in whole or in part, without the prior consent of TelVue Corporation.

# TOWN OF PUTNAM VALLEY

13

## Budget Adjustment Form

Year: 2023 Period: 12 Trans Type: B2 - Amend Status: Posted  
 Trans No: 118781 Trans Date: 12/29/2023 User Ref: MANGELICO  
 Requested: Approved: Created by: MANGELICO 01/17/2024  
 Description: YEAR END 2023 BUDGET AMENDMENTS Account # Order: Yes  
 Print Parent Account: No

| Account No.          | Account Description                     | Amount           |
|----------------------|-----------------------------------------|------------------|
| A.1110.130           | JUSTICE COURT.COMP EMPLOYEES            | 2,963.66         |
| A.1650.100           | CENTRAL COMMUNICATIONS.PERSONAL SERVICE | 5,412.70         |
| A.3620.130           | INSPECTORS.COMP EMPLOYEES               | 5,106.54         |
| A.5010.110           | HIGHWAY SUPT.PERSONAL SERVICE           | 0.04             |
| A.5010.130           | HIGHWAY SUPT.COMP EMPLOYEES             | 2,802.89         |
| A.7020.110           | RECREATION.PERSONAL SERVICE             | 3,726.00         |
| A.7020.120           | RECREATION.OFFICE STAFF                 | 2,105.58         |
| A.7020.130           | RECREATION.SR REC ASSISTANT             | 0.13             |
| A.7021.110           | PROGRAMS.PERSONNEL                      | 11,526.77        |
| A.7110.100           | PARKS/SPORTS.ADMINISTRATION             | 3,203.38         |
| A.7110.110           | PARKS.PERSONNEL                         | 4,775.05         |
| A.7310.110           | CHILDRENS CENTER.PERSONNEL              | 8,476.83         |
| A.8010.130           | ZONING.COMP EMPLOYEES                   | 1,528.15         |
| SW01.8320.416        | WATER PURCHASE                          | 5,170.55         |
| <b>Total Amount:</b> |                                         | <u>56,798.27</u> |

# TOWN OF PUTNAM VALLEY

## Budget Adjustment Form

Year: 2023 Period: 12 Trans Type: B2 - Amend Status: Posted  
 Trans No: 118811 Trans Date: 12/29/2023 User Ref: MANGELICO  
 Requested: Approved: Created by: MANGELICO 02/12/2024  
 Description: YTD 2023 ARPA EXPENDITURES Account # Order: Yes  
 Print Parent Account: No

| Account No.          | Account Description         | Amount           |
|----------------------|-----------------------------|------------------|
| A.1345.200           | PURCHASING - ARPA.EQUIPMENT | 24,299.52        |
| <b>Total Amount:</b> |                             | <u>24,299.52</u> |

## TOWN OF PUTNAM VALLEY

## Budget Adjustment Form

Year: 2023      Period: 12      Trans Type: B2 - Amend      Status: Posted  
Trans No: 118812      Trans Date: 12/29/2023      User Ref: MANGELICO  
Requested:      Approved:      Created by: MANGELICO      02/12/2024  
Description: TO ADJUST AMENDMENTS FOR RECEIPT OF COUNTY ARPA      Account # Order: Yes  
Print Parent Account: No

| Account No.          | Account Description           | Amount      |
|----------------------|-------------------------------|-------------|
| A.1345.424           | PURCHASING - ARPA CONTRACTUAL | -118,043.86 |
| <b>Total Amount:</b> |                               | -118,043.86 |



# TOWN OF PUTNAM VALLEY

## Budget Adjustment Form

|                                               |                        |                        |                      |
|-----------------------------------------------|------------------------|------------------------|----------------------|
| Year: 2023                                    | Period: 12             | Trans Type: B2 - Amend | Status: Posted       |
| Trans No: 118912                              | Trans Date: 12/29/2023 | User Ref: MANGELICO    |                      |
| Requested:                                    | Approved:              | Created by: MANGELICO  | 02/27/2024           |
| Description: 2023 YEAR END BUDGET ADJUSTMENTS |                        |                        | Account # Order: Yes |
| Print Parent Account: No                      |                        |                        |                      |

| Account No.          | Account Description          | Amount   |
|----------------------|------------------------------|----------|
| A.1440.410           | ENGINEER.STORMWATER PHASE II | 4,980.00 |
| <b>Total Amount:</b> |                              | 4,980.00 |
|                      |                              | 4,980.00 |

# TOWN OF PUTNAM VALLEY

## Budget Adjustment Form

|              |                                                         |             |            |             |                       |                  |            |
|--------------|---------------------------------------------------------|-------------|------------|-------------|-----------------------|------------------|------------|
| Year:        | 2023                                                    | Period:     | 12         | Trans Type: | B2 - Amend            | Status:          | Posted     |
| Trans No:    | 118932                                                  | Trans Date: | 12/29/2023 | User Ref:   | MANGELICO             |                  |            |
| Requested:   |                                                         | Approved:   |            | Created by: | MANGELICO             |                  | 02/27/2024 |
| Description: | TO RETURN PRIOR YEARS ARPA EXPENDITURES TO FUND BALANCE |             |            |             |                       | Account # Order: | Yes        |
|              |                                                         |             |            |             | Print Parent Account: | No               |            |

| Account No. | Account Description           | Amount          |
|-------------|-------------------------------|-----------------|
| A.1345.424  | PURCHASING - ARPA CONTRACTUAL | 3,750.00        |
|             | <b>Total Amount:</b>          | <b>3,750.00</b> |





# TOWN OF PUTNAM VALLEY

## Budget Adjustment Form

Year: 2023                                      Period: 12                      Trans Type: B2 - Amend                      Status: Posted  
 Trans No: 118936                      Trans Date: 12/29/2023                      User Ref: MANGELICO  
 Requested:                      Approved:                      Created by: MANGELICO                      02/27/2024  
 Description: TO COVER REMAINING YTD EXPENDITURES FROM 2023 STORM                      Account # Order: Yes  
 Print Parent Account: No

| Account No.          | Account Description | Amount                   |
|----------------------|---------------------|--------------------------|
| A.8676.100           | STORM 2023          | -150.00                  |
| A.8676.200           | STORM 2023          | 307,997.00               |
| A.8676.400           | STORM 2023          | 322,258.12               |
| <b>Total Amount:</b> |                     | <u><u>630,105.12</u></u> |

# TOWN OF PUTNAM VALLEY

## Budget Adjustment Form

Year: 2023                                  Period: 12                                  Trans Type: B2 - Amend                                  Status: Posted  
Trans No: 118947                                  Trans Date: 12/29/2023                                  User Ref: MANGELICO  
Requested:                                  Approved:                                  Created by: MANGELICO                                  03/07/2024  
Description: DECEMBER 2023 YTD BUDGET ADJUSTMENTS                                  Account # Order: Yes  
Print Parent Account: No

| Account No.          | Account Description           | Amount          |
|----------------------|-------------------------------|-----------------|
| A.1345.424           | PURCHASING - ARPA CONTRACTUAL | 8,330.00        |
| <b>Total Amount:</b> |                               | <u>8,330.00</u> |